

T.I.P.
TECHNIK + KOMPETENZ



PUMP TECHNOLOGY

T.I.P.

DEAR CUSTOMER,

We are delighted to present you with our catalogue for pump and watering technology. This new issue also includes everything you need to know and useful tips regarding drainage and watering, as well as domestic water supply. With our comprehensive range and years of experience in developing high quality pumps, we enable you to find a product that meets your requirements exactly. Separate catalogues list a wide range of other machines, tools and pool products.

40 YEARS OF DEVELOPING AND PRODUCING THE BEST IN PUMPS

Our company was founded in 1978 and specialised in developing, manufacturing and retailing water pumps. Quality was always the highest priority when selecting the appropriate ranges. Our in-house production facility has been ISO 9001-certified for many years and is subjected to strict checks by our product and quality management teams. This is how we can ensure very high production and product quality, taking our customers' requirements into account.

Thanks to our excellent value for money, T.I.P. has been one of the leading providers of pumps for private use in the home, on the farm and in the garden in Germany and across Europe for many years. We also sell our products successfully in countries outside Europe.

CONSTANT EVOLUTION AS A GUARANTEE FOR HIGH QUALITY

The success and high quality of our range is based on constant evolution of our products according to the latest technological developments. This is backed up by consistent implementation of the highest quality requirements when selecting materials and designing production processes. The impressive result of this approach is powerful and high quality pumps with excellent energy efficiency.

Saving water and using process water, groundwater and rain water instead of drinking water does not just reduce household costs but is also an active contribution to saving the environment. Safety also plays a vital role when developing our products. We therefore work continuously to evolve our products in conjunction with leading test institutes

T.I.P. ONLINE: A CUSTOMER-FRIENDLY SERVICE OFFERING

At www.tip-pumpen.de, we offer a comprehensive and well-organised website on which customer service is always at the forefront. Detailed information regarding products and accessories provides an informed insight into our range. Product information sheets are also available to print out. Any spare parts required can also be selected and ordered quickly from our online shop. As part of our regular updates, we present new products, describe innovative technologies and publish useful tips so visiting our homepage is always worth it.

SERVICE HOTLINE TO CLARIFY TECHNICAL QUERIES

We provide a hotline for technical queries as a special service. Our specialist staff will be happy to help you with queries regarding installation, maintenance or similar matters. Our technicians are available from Monday to Friday from 15:00 to 17:00 on +49 (0)7263-912550. Our service department is available for queries regarding spare parts and repairs. You can reach them during normal business hours on +49 (0)7263-91250 and by e-mail to service@tip-pumpen.de.

SPARE PARTS WITH 10 YEAR AVAILABILITY GUARANTEE

Our products meet high quality and reliability demands. However, our products are subject to normal wear and tear, which means that spare parts are required. In this regard, we would like to advise you of a service that is not common and that our customers value a great deal: we guarantee that spare parts will be available for 10 years. Spare parts are available for all products that are up to ten years old from the date of purchase. If repairs or spare parts are required, please contact us by post, by fax or by e-mail. Our contact details are on the last page in the catalogue.

Our website at www.tip-pumpen.de is the quickest and easiest way to order spare parts. The T.I.P. shop publishes exploded drawings and parts lists for our products so that a required part can be found and ordered in just a few clicks.

Have fun flicking through and reading the catalogue and many new suggestions.

TABLE OF CONTENTS

WATERING

- Submersible pressure pumps
- Deep well pumps
- Cistern pumps
- Garden pumps
- Smart garden pumps
- Automatic domestic water systems

S. 24-49

DOMESTIC WATER SUPPLY

Booster Sets with:
Plastic pump housing
Cast iron pump housing
Stainless steel pump housing
50 litre pressure vessel

S. 50-59

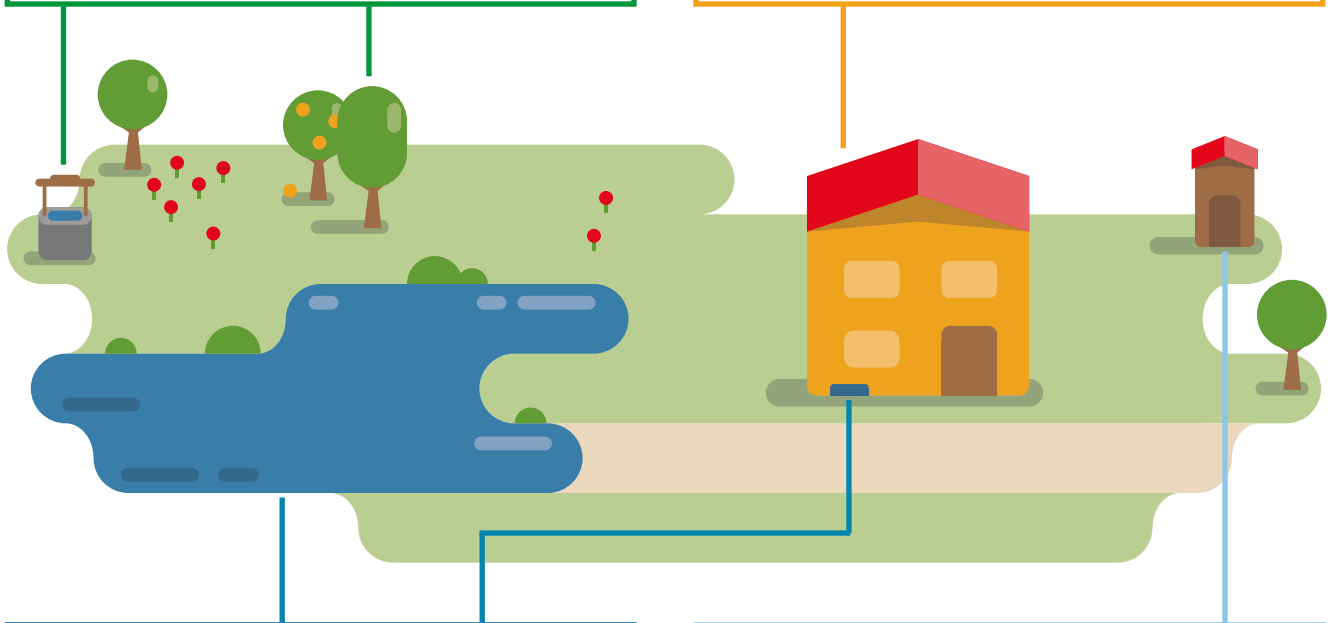

DRAINAGE

- Submersible drainage pumps
- Submersible clear water pumps
- Submersible dirty water pumps
- Flood Kit
- Dirty water construction pumps

S. 04-23

SPECIAL APPLICATIONS

- Solar powered irrigation system
- Motorised watering and drainage pumps
- Surface pumps for sandy water
- Heating circulation pumps

S. 60-69

ACCESSORIES

- Miscellaneous
- Filters
- Hoses
- Connections
- IBC connections
- Pressure vessels

S. 70-81



PUMPS FOR DRAINAGE

Our range of drainage technology offers the right product for every purpose.

- *Transferring clear, waste or salt water*
- *Flat suction drainage (mop-dry)*
- *Use in drainage shafts*
- *Transferring and pumping out trenches or pools*
- *Pumping out construction trenches*

Our pumps are made of high quality materials, have energy-efficient copper coils and thermal motor protection.



SUBMERSIBLE DRAINAGE PUMPS

Submersible drainage pumps are designed for special applications. Thanks to their compact design, vertical pump outlet and integrated float switch, they are ideal for use in narrow drainage shafts.



SUBMERSIBLE CLEAR WATER PUMPS

Clear water pumps are ideal for pumping out or decanting clean or slightly contaminated liquids. Typical applications are pumping domestic waste water, rainwater or seepage water and pumping out pools.



SUBMERSIBLE DIRTY WATER PUMPS

The area of application comprises a wide range from slightly to heavily contaminated fluids. These include typical applications such as emptying garden ponds, pools, cisterns or emergency drainage. Some models are suitable for continuous operation and circulation.



FLOOD KIT

Our high water sets are put together in such a way that they are perfectly suited to basement drainage. The set contains a tried and tested drainage pump, a filter basket, a high quality textile hose and all connections. Use the pump with or without a filter basket.



DIRTY WATER CONSTRUCTION PUMPS

Emptying waste water pits has very high requirements. The specially-developed waste water construction pumps therefore feature a special high-quality design and technology. The VORTEX impeller system ensures trouble-free operation when water with coarse particles has to be removed very quickly and pumps have to work with maximum efficiency and reliability.

DRAINAGE
SUBMERSIBLE DRAINAGE PUMPS



SUITABLE FOR
CLEAR WATER



SUITABLE FOR
WASTE WATER



I-COMPAC SERIES

- » For pumping clear and contaminated water
- » Compact design for narrow drainage shafts
- » Dry running protection due to integrated float switch for automatic or manual mode
- » Vertical pump outlet
- » Including multi-dimensional connection port for various connection sizes

DRAINAGE SUBMERSIBLE DRAINAGE PUMPS

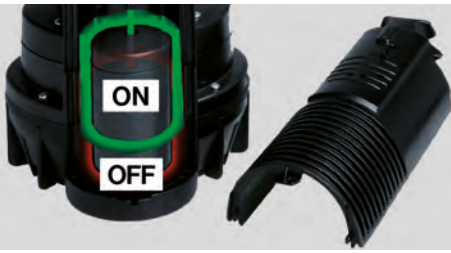

FLOAT SWITCH

Connectible built-in float switch for automatic operation.

VERTICAL PUMP OUTLET

Since the pump outlet is directed upwards, this allows for a compact installation in tight spaces or shafts and simplifies the routing of pipes when lateral space is limited.



USE IN NARROW SHAFTS

These pumps are designed for use in drainage shafts with minimum dimensions of 22x22 cm.



Product range



I-COMPAC 7500



I-COMPAC 13000

Special features

- Submersible waste water drainage pump
- For drainage shafts from 22 x 22 cm

- Submersible waste water drainage pump
- For drainage shafts from 22 x 22 cm

Max. delivery rate

7,500 l/h

13,000 l/h

Max. delivery height / max. pressure

5 m / 0.5 bar

9 m / 0.9 bar

Rated power

400 watts

750 watts

Max. immersion depth

5 m

7 m

Pump outlet

47.80 mm (1 1/2" outside thread)

Min. suction level

25 mm

25 mm

Max. grain size

16 mm

16 mm

Item number

30190

30191

EAN / GTIN

4011458301904

4011458301911

Delivery rate depends on the delivery height

(measured from the water surface)

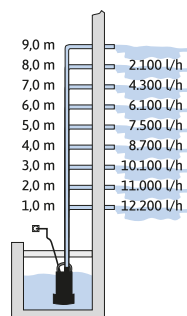
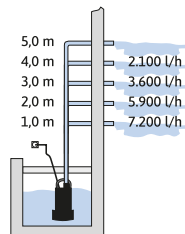

DRAINAGE
SUBMERSIBLE CLEAR WATER PUMPS



SUITABLE FOR
CLEAR WATER



FLATONE 6000 IX

- » Perfect for pumping out or transferring water from your pool
- » The special pump foot prevents pool liners being sucked in
- » For flat suction down to 1 mm of water in manual mode
- » Dry running protection thanks to a float switch
- » Lockable float switch for automatic or manual mode
- » Stainless steel pump housing
- » Including multi-dimensional connection port for various connection sizes

DRAINAGE SUBMERSIBLE CLEAR WATER PUMPS

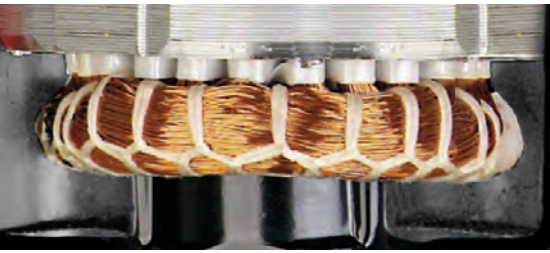

ENERGY EFFICIENT MOTOR

Like all T.I.P. pumps, these pump model feature a very energy-efficient motor coil made of high-quality copper. The pumps are therefore very economical and environmentally friendly.

POOL LINER

The specially developed pump foot on the FlatOne 6000 IX (for flat suction down to 1 mm of water) prevents the swimming pool or pool liner being sucked in.



FLOAT

Dry running protection thanks to the float switch's automatic on/off switch.



Product range

FlatOne 6000 IX

Special features

- For flat suction down to 1 mm (mop-dry)
- Prevents the pool liner being sucked in
- Forced motor cooling for flat water operation
- With check valve

Max. delivery rate 6,000 l/h

Max. delivery height / max. pressure 6 m / 0.6 bar

Rated power 300 watts

Max. immersion depth 7 m

Pump outlet 39.59 mm (1 1/4" inside thread)

Min. suction level 1 mm

Max. grain size 1 mm

Item number 30440

EAN / GTIN 4011458304400

Delivery rate depends on the delivery height

(measured from the water surface)

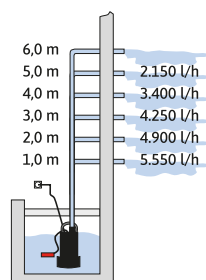

DRAINAGE SUBMERSIBLE DIRTY WATER PUMPS



SUITABLE FOR
CLEAR WATER



SUITABLE FOR
WASTE WATER



DTX & TVX

- » Suitable for pumping out or transferring waste water
- » The DTX range is also suitable for continuous operation
- » VORTEX free flow impeller system for trouble-free operation
- » Optimum installation and storage with the TPT 20 mounting system (included on the DTX 7500 T)
- » Glass fibre-reinforced plastic pump housing
- » Dry running protection thanks to a float switch
- » Lockable float switch for automatic or manual mode
- » All models equipped with hose connection accessories

DRAINAGE

SUBMERSIBLE DIRTY WATER PUMPS

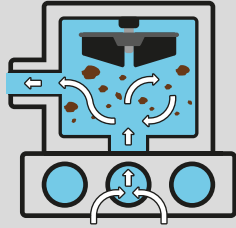

TROUBLE-FREE OPERATION

The VORTEX free flow impeller prevents pump blockages efficiently by swirling dirt particles around and breaking them down.

ACCESSORIES

The special TPT 20 mounting system and fish protection grille are available as accessories (included with the DTX 7500 T).



DURABLE MOTOR

High efficiency and durability due to the copper coil. Therefore, all T.I.P. pumps are very economical and environmentally friendly. DTX model: Ceramic-coated motor shaft for low-wear continuous operation and circulation.

Product range



TVX
7000



TVX
12000



DTX
7500 T



DTX
15000

The TVX and DTX range have a **VORTEX** impeller. The DTX range is also suitable for **continuous operation and circulation**.

Special features

- Including mounting system and protective grille for fish ponds
- Including protective grille for fish ponds

Special features	TVX 7000	TVX 12000	DTX 7500 T	DTX 15000
Max. delivery rate	7,000 l/h	10,800 l/h	7,500 l/h	15,000 l/h
Max. delivery height / max. pressure	5 m / 0.5 bar	6 m / 0.6 bar	6 m / 0.6 bar	8 m / 0.8 bar
Rated power	300 watts	480 watts	320 watts	600 watts
Max. immersion depth	7 m	7 m	7 m	7 m
Pump outlet	41.91 mm (1 ¼" outside thread)	41.91 mm (1 ¼" outside thread)	41.91 mm (1 ¼" outside thread)	41.91 mm (1 ¼" outside thread)
Min. suction level	30 mm	30 mm	30 mm	30 mm
Max. grain size	20 mm	20 mm	22 mm	22 mm
Item number	30268	30261	30258	30257
EAN / GTIN	4011458302680	4011458302611	4011458302581	4011458302574

Delivery rate depends on the delivery height (measured from the water surface)

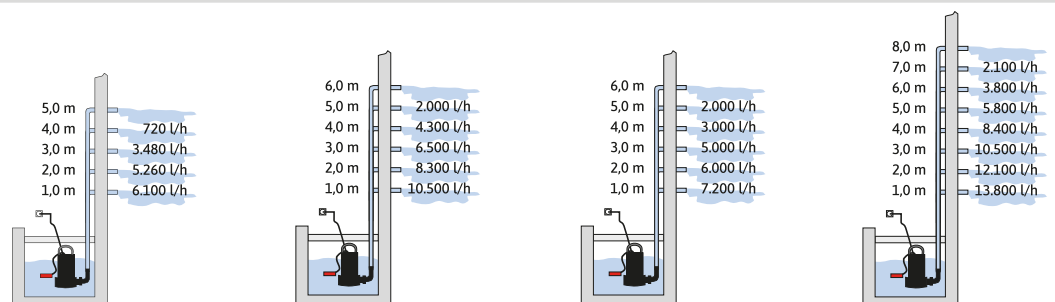

DRAINAGE
SUBMERSIBLE DIRTY WATER PUMPS



SUITABLE FOR
CLEAR WATER



SUITABLE FOR
WASTE WATER



MAXIMA RANGE

- » High performance submersible waste water pumps
- » High delivery rate due to optimised pump hydraulics
- » High-quality stainless steel motor housing
- » Glass fibre-reinforced plastic or stainless steel pump housing
- » Dry running protection thanks to a float switch
- » Lockable float switch for automatic or manual mode
- » All models equipped with hose connection accessories

DRAINAGE SUBMERSIBLE DIRTY WATER PUMPS



ROBUST HYDRAULIC UNIT

The Maxima range has robust, durable pump hydraulics made of different materials for each model.

LOCKABLE FLOAT SWITCH

For automatic or manual operation. Additionally, the pumps are equipped with thermal overload protection that automatically shuts off the pump in case of overheating to prevent damage.



HIGH-QUALITY MOTOR HOUSING

Housing made of high-quality rustproof stainless steel.

Product range



Maxima 180 PX



Maxima 250 PX



Maxima 300 IX

The motor housing for the Maxima range is made of **high quality** and **rustproof stainless steel**.

Special features

• Plastic pump housing

• Plastic pump housing

• Stainless steel pump housing

Max. delivery rate

10,500 l/h

14,500 l/h

18,000 l/h

Max. delivery height / max. pressure

7 m / 0.7 bar

8 m / 0.8 bar

8 m / 0.8 bar

Rated power

500 watts

600 watts

700 watts

Max. immersion depth

7 m

7 m

7 m

Pump outlet

41.91 mm (1 1/4" outside thread)

41.91 mm (1 1/4" outside thread)

47.80 mm (1 1/2" outside thread)

Min. suction level

37 mm

37 mm

40 mm

Max. grain size

25 mm

25 mm

30 mm

Item number

30121

30264

30116

EAN / GTIN

4011458301218

4011458302642

4011458301164

Delivery rate depends on the delivery height

(measured from the water surface)

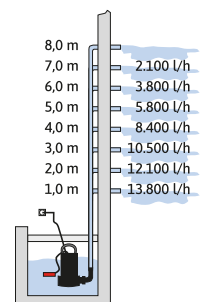
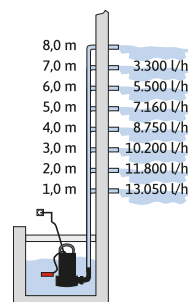
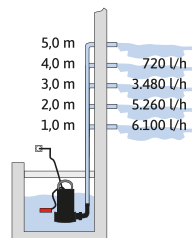

DRAINAGE SUBMERSIBLE DIRTY WATER PUMPS



SUITABLE FOR
CLEAR WATER



SUITABLE FOR
WASTE WATER



MAXIMA RANGE

- » Exceptionally robust and efficient construction pump (Maxima 400 CX)
- » High delivery rate due to optimised pump hydraulics
- » Motor housing made of high-quality stainless steel
- » Pump housing made of stainless steel or cast iron
- » Extendable pump foot (Maxima 350 IPX DUO) as an all-round model
- » Protection against dry running by float switch
- » Lockable float switch for automatic or manual operation
- » All models equipped with hose connection accessories

DRAINAGE

SUBMERSIBLE DIRTY WATER PUMPS



EXTENDABLE PUMP BASE

The Maxima 350 IPX DUO can be transformed from a powerful dirty water pump (35 mm residual water level) into a shallow suction clear water pump (1 mm residual water level) in one easy step.

MAXIMA SERIES

The Maxima 400 CX is equipped with self-lubricating precision ball bearings and is therefore suitable for difficult tasks such as construction pit drainage.

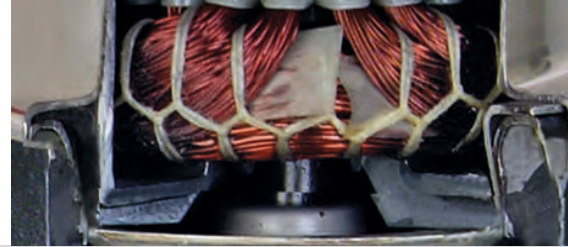

HIGH FLOW RATE

The optimised pump hydraulics of the Maxima series provide for the extraordinarily high flow rate of 10,500 to 24,000 l/h.



Maxima 350 IPX DUO



Maxima 400 CX

Product range

Special features

- Combination submersible pump with extendable pump base
- Suction level 1 mm (clear water)
- Ideal for emergency drainage in case of flooding (clear & dirty water)
- Stainless steel motor and pump housing

- Ball bearings running in oil bath
- Open cast impeller
- Stainless steel motor and robust cast iron pump casing

Max. delivery rate 20,000 l/h

24,000 l/h

Max. delivery height / max. pressure 8 m / 0.8 bar

9 m / 0.9 bar

Rated power 800 watts

950 watts

Max. immersion depth 7 m

7 m

Pump outlet 47.80 mm (1 1/2" outside thread)

45.48 mm (1 1/2" inside thread)

Min. suction level 1 mm / 35 mm

40 mm

Max. grain size 1 mm / 30 mm

35 mm

Item number 30274

30140

EAN / GTIN 4011458302741

4011458301409

Delivery rate depends on the delivery height
(measured from the water surface)

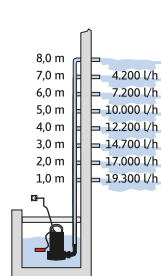

Dirty water operation

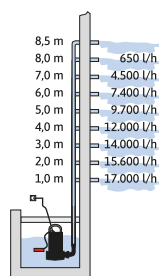

Clear water operation

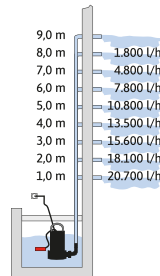



SUITABLE FOR
CLEAR WATER



SUITABLE FOR
WASTE WATER



FLOOD KIT

- » Complete set for basement drainage with pump, filter basket and accessories
- » Pumps: I-COMPAC 13000 or Maxima 350 IPX DUO in the high water set
- » The practical filter basket is used as a coarse filter and a storage box
- » The filter basket enables trouble-free pump operation
- » Accessories comprising a tear-resistant textile hose (15 m) including C-Storz couplings
- » All models equipped with additional hose connection accessories

DRAINAGE FLOOD KIT



TRIED AND TESTED PUMPS

Whether it's the high water set or a single pump, our pumps are also strong alone. For more information on the I-COMPAC 13000 submersible drainage pump, see page 07 and for more information on the Maxima 350 IPX DUO submersible waste water pump, see page 15.

PRACTICAL FILTER BASKET

The filter basket is used as a coarse filter and a practical storage box for the pump, hose and accessories. Furthermore, the basket filters coarse particles and therefore prevents pump blockages.

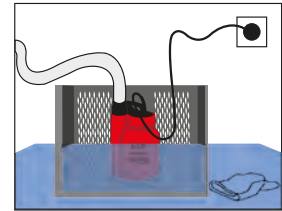

TEXTILE HOSE WITH COUPLING

Includes a 15 m textile hose with a pre-fitted C-Storz coupling and a corresponding C-Storz coupling for the pump. Can be connected or released with just one hand movement.



Product range



Flood kit
I-COMPAC 13000 S



Flood kit
Maxima 350 IPX DUO S

Special features

- For narrow shafts as of 20 x 20 cm
- Vertical pump outlet
- Integrated float switch

- Combination submersible pump with extendible pump foot
- 1 mm suction level (clear water)
- Grain size 30 mm (waste water)
- Stainless steel motor and pump housing

Max. delivery rate 13,000 l/h

20,000 l/h

Max. delivery height / max. pressure 9 m / 0.9 bar

8 m / 0.8 bar

Rated power 750 watts

800 watts

Max. immersion depth 7 m

7 m

Pump outlet 47.80 mm (1 1/2" outside thread)

47.80 mm (1 1/2" outside thread)

Min. suction level 25 mm

1 mm / 35 mm

Max. grain size 16 mm

1 mm / 30 mm

Item number 30702

30711

EAN / GTIN 4011458307029

4011458307111

Delivery rate depends on the delivery height
(measured from the water surface)

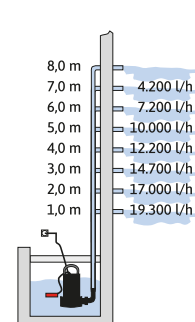
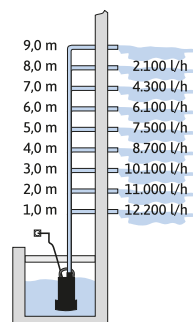

Dirty water operation

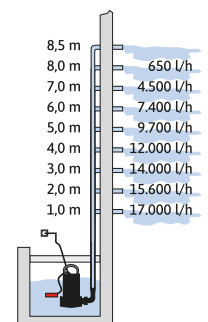

Clear water operation

DRAINAGE
DIRTY WATER CONSTRUCTION PUMPS



SUITABLE FOR
CLEAR WATER



SUITABLE FOR
WASTE WATER



EXTREMA RANGE

- » Suitable for dewatering under extreme conditions
- » Special models for continuous operation and liquid temperatures of up to 95 °C
- » Durable pump thanks to high-quality, cast VORTEX precision impellers
- » Ball bearings running in an oil bath for smooth operation of your pump
- » All IX models are suitable for pumping detergent solution
- » Robust cast iron or stainless steel AISI 304 pump housing
- » Dry running protection thanks to a float switch
- » Lockable float switch for automatic or manual mode
- » All models equipped with hose connection accessories

DRAINAGE

DIRTY WATER CONSTRUCTION PUMPS



HIGH-QUALITY COMPONENTS

The high-quality, robust housings and precision-cast impellers in the EXTREMA range are made of cast iron or stainless steel (AISI 304).

TROUBLE-FREE OPERATION

This system prevents pump blockages efficiently by swirling dirt particles around and breaking them down.

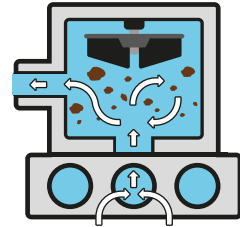

HIGH TEMPERATURE RANGES

Specially developed for pumping hot liquids of up to 50 °C and for short periods (approx. 4 min), up to 95 °C.

Product range



The motor housing for the EXTREMA range is made of high-quality stainless steel. The range is suitable for liquids of up to 50 °C and for short periods (approx. 4 min), up to 95 °C.

Special features

- | | | | |
|--|--|--|--|
| <ul style="list-style-type: none"> • Cast precision stainless steel impeller • Suitable for detergent solution | <ul style="list-style-type: none"> • Vertical pump outlet • Robust cast iron pump housing with cast impeller | <ul style="list-style-type: none"> • Cast precision stainless steel impeller • Suitable for detergent solution | <ul style="list-style-type: none"> • Vertical pump outlet • Robust cast iron pump housing with cast impeller |
|--|--|--|--|

Max. delivery rate	19,500 l/h	24,000 l/h	30,000 l/h	36,000 l/h
Max. delivery height / max. pressure	10.5 m / 1.05 bar	11 m / 1.1 bar	13 m / 1.3 bar	14 m / 1.4 bar
Rated power	1,200 watts	1,500 watts	1,800 watts	2,200 watts
Max. immersion depth	7 m	7 m	7 m	7 m
Pump outlet	47.80 mm (1 1/2" outside thread)	57.29 mm (2" inside thread)	59.61 mm (2" outside thread)	57.29 mm (2" inside thread)
Min. suction level	55 mm	55 mm	65 mm	65 mm
Max. grain size	40 mm	40 mm	45 mm	50 mm
Item number	30072	30168	30171	30194
EAN / GTIN	4011458300723	4011458301683	4011458301713	4011458301942

Delivery rate depends on the delivery height (measured from the water surface)

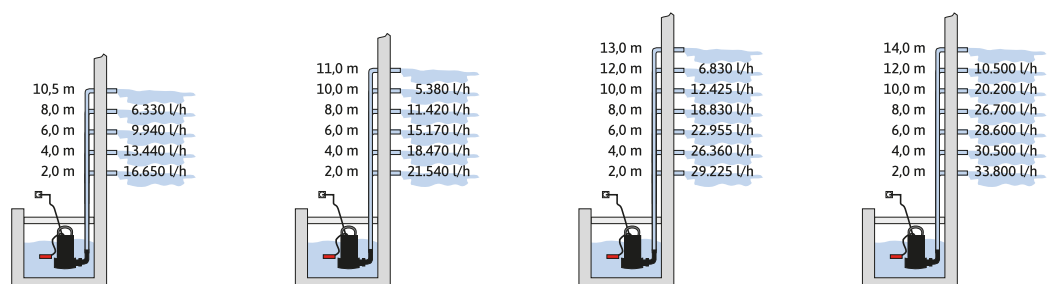

DRAINAGE DIRTY WATER CONSTRUCTION PUMPS



SUITABLE FOR
CLEAR WATER



SUITABLE FOR
WASTE WATER



EXTREMA RANGE

- » Suitable for dewatering under extreme conditions
- » For continuous operation and liquid temperature up to 90 °C (EXTREMA CUT 300/18 CX) or 95 °C (EXTREMA 700/16-3 IX)
- » Durable pump thanks to high-quality, cast VORTEX precision impellers
- » Ball bearings running in an oil bath for smooth operation of your pump
- » High-quality stainless steel motor housing
- » Robust cast iron or stainless steel AISI 304 pump housing
- » EXTREMA 700/16-3 IX: 3-phase pump, suitable for detergent solution
- » EXTREMA CUT 300/18 CX: High-performance cutting unit to break down solids, including lockable float switch for automatic or manual mode and for dry running protection
- » All models equipped with hose connection accessories

DRAINAGE

DIRTY WATER CONSTRUCTION PUMPS



REAMER GRINDING CUTTING UNIT

The high-performance cutting unit on the EXTREMA CUT 300/18 CX breaks up solids reliably.

SUITABLE FOR NON-STOP RUNNING

Ceramic-coated motor shaft, high-quality copper coil and oil bath-lubricated ball bearings - these attributes give the motor for the EXTREMA range its suitability for non-stop running.

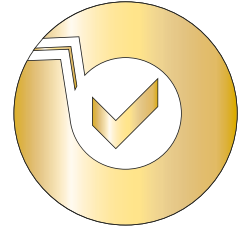

3-PHASE PUMP

The 400 V EXTREMA 700/16-3 IX pump with its unique delivery rate of up to 42,000 l/h and a delivery height of up to 16 m is the ultimate in waste water pumps.



EXTREMA CUT 300/18 CX



EXTREMA 700/16-3 IX

Product range

Special features

- Reamer Grinding cutting unit
- Robust cast iron pump housing
- Vertical pump outlet
- For a short time (approx. 4 min), up to 90 °C

- 3-phase motor (400 V)
- Suitable for detergent solution
- Stainless steel pump housing and impeller
- For a short time (approx. 4 min), up to 95 °C

Max. delivery rate 18,000 l/h

42,000 l/h

Max. delivery height / max. pressure 18 m / 1.8 bar

16 m / 1.6 bar

Rated power 2,000 watts

2,500 watts

Max. immersion depth 7 m

7 m

Pump outlet 57.29 mm (2" inside thread)

59.61 mm (2" outside thread)

Min. suction level 70 mm

65 mm

Max. grain size 50 mm

50 mm

Item number 30277

30275

EAN / GTIN 4011458302772

4011458302758

Delivery rate depends on the delivery height
(measured from the water surface)

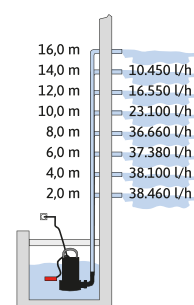
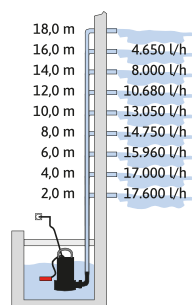

DRAINAGE
DIRTY WATER CONSTRUCTION PUMPS



SUITABLE FOR
CLEAR WATER



SUITABLE FOR
WASTE WATER



SUITABLE FOR
SALT WATER



EXTREMA & SALTONE

- » Top of the range salt water special model
- » For continuous operation and liquid temperatures of up to 90 °C (SaltOne) or 95 °C (EXTREMA)
- » Durable pump thanks to high-quality, cast VORTEX precision impellers
- » Ball bearings running in an oil bath for smooth operation of your pump
- » High-quality stainless steel motor housing and pump housing
- » Suitable for pumping detergent solution
- » Lockable float switch for automatic or manual mode
- » Including multi-dimensional connection port for various connection sizes

DRAINAGE

DIRTY WATER CONSTRUCTION PUMPS



SALT WATER AND DETERGENT SOLUTION

These models pump both salt water and detergent solution reliably.

HIGH TEMPERATURE RANGES

In continuous operation: Immersed completely in the medium to be pumped, both models are suitable for fluids of up to 50 °C. On the SaltOne 16000 I-PX DUO, suitability for non-stop running at up to 35 °C is also guaranteed if the motor is located outside the medium to be pumped.

For a short time: The models pump liquids of over 90 °C (for approx. 4 min).



2 IN 1 PUMP

Our specially developed DUO ring gives the SaltOne 16000 I-PX DUO its flat suction properties (2 mm). When operating without the DUO ring, dirt particles with a grain size of up to 10 mm can be pumped.



SaltOne 16000 I-PX DUO



EXTREMA 450/12 IX-S

Product range

The motor and pump housing for this range is made of high-quality stainless steel. Both models pump detergent solution and liquids of up to 50 °C.

Special features

- For salt water (max. 10 %)
 - High-quality stainless steel (AISI 316)
 - With welded stainless steel impeller and check valve
 - For a short time (approx. 4 min), for 90 °C
 - 2 in 1 pump thanks to the DUO ring
 - Forced motor cooling for flat water operation
- For salt water (4 %)
 - High-quality stainless steel (AISI 304)
 - Cast precision stainless steel impeller
 - For a short time (approx. 4 min), for 95 °C

Max. delivery rate	16,000 l/h	27,000 l/h
Max. delivery height / max. pressure	10 m / 1.0 bar	12 m / 1.2 bar
Rated power	900 watts	1,500 watts
Max. immersion depth	7 m	7 m
Pump outlet	39.59 mm (1 1/4" inside thread)	59.61 mm (2" outside thread)
Min. suction level	16 mm / 2 mm	55 mm
Max. grain size	10 mm / 2 mm	40 mm
Item number	30276	30278
EAN / GTIN	4011458302765	4011458302789

Delivery rate depends on the delivery height
(measured from the water surface)

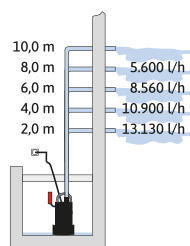

with DUO-Ring

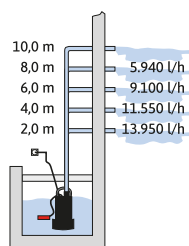

without DUO-Ring

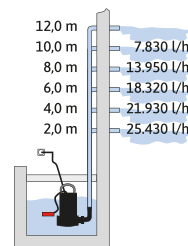



PUMPS FOR WATERING

Our extensive range of watering technology offers the right product for every purpose.

- *Transferring at high pressure*
- *Pumping from great depths and narrow drilled wells*
- *Watering lawns, beds, etc.*
- *Operating watering systems*
- *Transferring and pumping out trenches and pools*
- *Transferring service water for the garden and house*

Our pumps are made of high quality materials, have energy-efficient copper coils and thermal motor protection.



SUBMERSIBLE PRESSURE PUMPS

Submersible pressure pumps are ideal for transferring water at high pressure. For this reason, they are well suited for operating sprinklers. Watering lawns or beds directly from wells or storage containers is therefore child's play. Thanks to its compact design, variable and mobile use of these pumps in different places is also possible



DEEP WELL PUMPS

Deep well pumps are specially designed and highly efficient multi-stage submersible pressure pumps to pump clear water from great depths without problems. The standard equipment comprises a long connection cable and a special rope to lower the pumps. Due to their special design and technology, they are used in narrow drilled wells as of a diameter of 8 cm.



CISTERN PUMPS

Cistern pumps are specially designed, highly efficient multi-stage submersible pressure pumps for use in cisterns, pools or wells. Thanks to the high delivery rate and the high delivery pressure, they are suitable for supplying your house with service water without problems. The special intake opening enables trouble-free operation with a floating suction set



GARDEN PUMPS

Garden pumps are distinguished by their enormous range of applications. They are ideal for removing water from wells or streams and to transfer and pump out pools. High-pressure water pumping enables watering systems to be operated without problems. All of our models are equipped with a self-priming hydraulic system.



AUTOMATIC DOMESTIC WATER SYSTEMS

An automatic domestic water system is an automated garden pump. This means that the liquid can be used just like water from the mains. By opening and closing consumers (tap, etc.), the pump switches ON and OFF automatically as required. Classic applications are therefore pumping clean water, service water and rain water automatically. They are also used in the domestic water supply.

WATERING SUBMERSIBLE PRESSURE PUMPS

SUITABLE FOR
CLEAR WATER



SUITABLE FOR
DRAINAGE



SUITABLE FOR
IRRIGATION



SUBMERSIBLE PRESSURE PUMPS

- » Suitable for direct watering from wells or storage containers
- » Transferring water at high pressure
- » For manual and automatic watering with sprinklers
- » Can be used as a shallow suction pump in manual operation (1 mm)
- » Glass fibre-reinforced plastic or high-quality stainless steel pump housing
- » Dry running protection thanks to a float switch
- » Lockable float switch for automatic or manual mode
- » Complete set for watering and drainage with 10 m hose, rain barrel accessories, sprinkler, garden sprayer, garden sprayer and all connections

WATERING SUBMERSIBLE PRESSURE PUMPS



ROBUST HOUSING

High-quality, glass fibre reinforced housing with lockable float switch for manual operation.

FLAT SUCTION CAPABILITY

Mop-dry drainage down to 1 mm of water in manual operation.



CITY GARDENING

Ideal for watering city gardens and for drainage of minor domestic water damage.



DrainPress 3200/24



DrainPress 3200/24 Set

Product range

The multifunction pump is ideally suited for watering and draining. Thanks to the vertical pump outlet with hose connection coupling it is particularly convenient.

Special features

- Complete set: 10 m hose, rain barrel accessories, sprinkler, garden sprayer, garden sprayer and all connections

Max. delivery rate

3,200 l/h

3,200 l/h

Max. delivery height / max. pressure

24 m / 2.4 bar

24 m / 2.4 bar

Rated power

400 watts

400 watts

Max. immersion depth

7 m

7 m

Max. contaminant particle size

2 mm

2 mm

Pressure connection

26.44 mm (3/4" outside thread)

26.44 mm (3/4" outside thread)

Item number

30182

30181

EAN / GTIN

4011458301829

4011458301812

Delivery rate depends on the delivery height
(measured from the water surface)

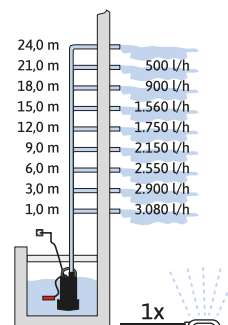
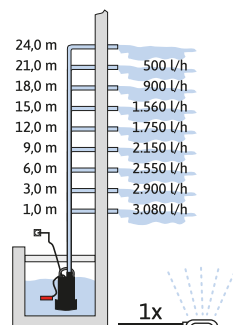

WATERING SUBMERSIBLE PRESSURE PUMPS



SUITABLE FOR
CLEAR WATER



SUITABLE FOR
DRAINAGE



SUITABLE FOR
IRRIGATION



SUBMERSIBLE PRESSURE PUMPS

- » Suitable for direct watering from wells or storage containers
- » Transferring water at high pressure
- » For manual and automatic watering with sprinklers (DRAIN 6000/36)
- » Can be controlled electronically with BRIO 2000-M (DRAIN 6000/36)
- » Glass fibre-reinforced plastic or high-quality stainless steel pump housing
- » Dry running protection thanks to a float switch
- » Lockable float switch for automatic or manual mode
- » All models equipped with hose connection accessories

WATERING SUBMERSIBLE PRESSURE PUMPS



ROBUST HOUSING

The DRAIN 6000/36 has a high-quality pump housing and a motor shaft made of stainless steel and is therefore particularly robust.

HIGH PRESSURE

Thanks to its high pressure, the DRAIN 6000/36 is ideally suited for watering large gardens, with up to 4 sprinklers.



USE IN RAIN BARRELS

Specially designed rain barrel pump (DIO 45/13 flex) for convenient watering nozzle operation. The DRAIN range is suitable for more pressure.



DIO 45/13 flex



DRAIN 6000/36

Product range

Special features

- Flow rate regulator, fastening clip and three riser elements
- Convenient vertical pump outlet and hose connection coupling

- Suitable for automation with BRIO 2000-M
- Stainless steel motor housing and motor shaft

Max. delivery rate

2,700 l/h

6,000 l/h

Max. delivery height / max. pressure

13 m / 1.3 bar

34 m / 3.4 bar

Rated power

350 watts

950 watts

Max. immersion depth

5 m

7 m

Max. contaminant particle size

2 mm

2 mm

Pressure connection

26.44 mm (3/4" outside thread)

41.91 mm (1 1/4" outside thread)

Item number

30263

30136

EAN / GTIN

4011458302635

4011458301362

Delivery rate depends on the delivery height
(measured from the water surface)

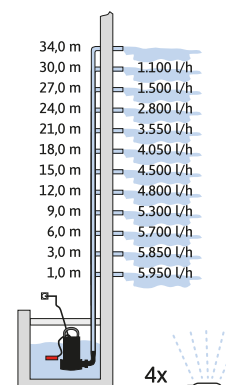
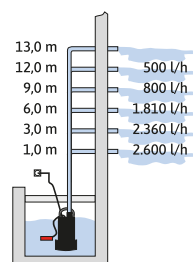

WATERING DEEP WELL PUMPS



SUITABLE FOR
CLEAR WATER



SUITABLE FOR
IRRIGATION



SUITABLE FOR
DOMESTIC WATER



AJ RANGE

- » Suitable for pumping clear water from great depths and transferring it under high pressure
- » For drilled wells from Ø 8 cm (AJ 3 Plus 50/55) or Ø 10 cm (AJ 4 series)
- » Suitable for automatic water supply with BRIO 2000-M
- » All models have a connection cable (23 m) and a lowering rope
- » Multi-stage pump hydraulics with floating impellers

WATERING DEEP WELL PUMPS



FLOATING IMPELLERS

These pumps feature multi-stage pump hydraulics with floating impellers.

AUTOMATION

Deep well pumps are ideal for automation with the BRIO 2000-M. (page 76)



HIGH-QUALITY STAINLESS STEEL HOUSING

The pumps in this range have a water-cooled motor and stainless steel housing.

Product range



**AJ 4 Plus
55/50**



**AJ 4 Plus
95/40**



**AJ 3 Plus
50/55**

Special features

The **AJ 4 Plus** range is suitable for narrow drilled wells as of a diameter of 10 cm.
The **AJ 3 Plus** range is suitable for narrow drilled wells as of a diameter of 8 cm.

Max. delivery rate	3,300 l/h	5,500 l/h	3,000 l/h
Max. delivery height / max. pressure	50 m / 5.0 bar	40 m / 4.0 bar	55 m / 5.5 bar
Rated power	800 watts	900 watts	800 watts
Max. immersion depth	20 m	20 m	20 m
Max. contaminant particle size	≤ 1 mm / 50 g/m ³	≤ 1 mm / 50 g/m ³	≤ 1 mm / 50 g/m ³
Pressure connection	39.59 mm (1 1/4" inside thread)	39.59 mm (1 1/4" inside thread)	30.93 mm (1" inside thread)
Minimum efficiency index (MEI)	≥ 0.40	≥ 0.40	≥ 0.40
Item number	30104	30177	30081
EAN / GTIN	4011458301041	4011458301775	4011458300815

Delivery rate depends on the delivery height
(measured from the water surface)

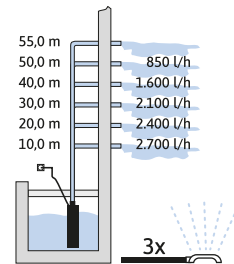
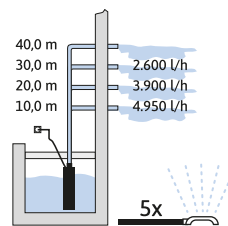
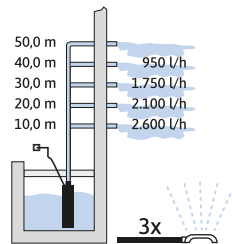

WATERING DEEP WELL PUMPS



SUITABLE FOR
CLEAR WATER



SUITABLE FOR
IRRIGATION



SUITABLE FOR
DOMESTIC WATER



MSC RANGE

- » Suitable for pumping clear water from great depths
- » For drilled wells as of a diameter of 8 cm (MSC 3/3 M) or 10 cm
- » Ready for connection with external capacitor box
- » All models have a connection cable (15 or 23 m) and a tear-resistant lowering rope

WATERING DEEP WELL PUMPS



EXTERNAL CONTROL UNIT

The external capacitor box allows you to adjust cable length and submersion depth freely as required.

ROBUST

The hydraulic system (brass impeller) on the MSC 4/1 M and the MSC 3/3 M is suitable for a sand component of up to 0.15 % (150 g/m³) in the pumped liquid.



76 mm

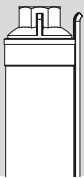

76 mm

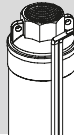

SUITABLE FOR NARROW DRILLED WELLS

Thanks to the low outer diameter of 7.6 cm, the MSC 3/3 M is suitable for narrow 3" (8 cm) drilled wells.

Product range



MSC 3/3 M



MSC 4/1 M



MSC 4/10

Special features

- 3" pump Ø 7.6 cm
- Stainless steel/brass pump housing with brass impellers
- Peripheral impeller system for high sand-resistance

- 4" pump Ø 9.8 cm
- Stainless steel/brass pump housing with brass impeller
- Peripheral impeller system for high sand-resistance

- 4" pump Ø 9.8 cm
- Stainless steel/brass pump housing
- 10 impellers

Max. delivery rate	2,520 l/h	3,000 l/h	5,500 l/h
Max. delivery height / max. pressure	58 m / 5.8 bar	56 m / 5.6 bar	72 m / 7.2 bar
Rated power	1,100 watts	1,300 watts	1,300 watts
Max. immersion depth	12 m	12 m	20 m
Max. contaminant particle size	2 mm / 150 g/m ³	2 mm / 150 g/m ³	2 mm / 100 g/m ³
Pressure connection	30.93 mm (1" inside thread)	30.93 mm (1" inside thread)	39.59 mm (1 ¼" inside thread)
Minimum efficiency index (MEI)	-	-	≥ 0.40
Impeller system	Brass / 3 impellers	Brass / 1 impeller	Plastic / 10 impellers
Item number	30192	30176	30193
EAN / GTIN	4011458301928	4011458301768	4011458301935

Delivery rate depends on the delivery height
(measured from the water surface)

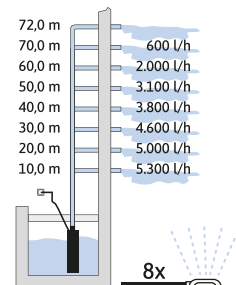
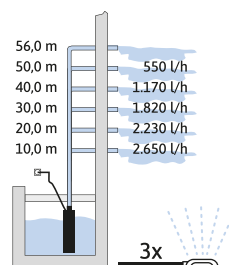
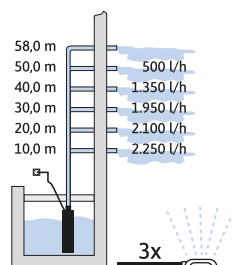

WATERING DEEP WELL PUMPS



SUITABLE FOR
CLEAR WATER



SUITABLE FOR
IRRIGATION



SUITABLE FOR
DOMESTIC WATER



BIGWELL RANGE

- » To pump clear water from great depths
- » Suitable for narrow shafts and pipes with a diameter of 10 cm or more
- » Extendable foot protects against silting of the pump hydraulics
- » BigWell 90/53 is suitable for automatic water supply through the BRIO 2000-M
- » Including connection cable (23 m) and lowering rope
- » Multi-stage pump hydraulics with floating impellers
- » Integrated thermal overload protection as well as integrated check valve

WATERING DEEP WELL PUMPS



FLOATING IMPELLERS

These pumps feature multi-stage pump hydraulics with floating impellers.

AUTOMATION

Deep well pumps are ideal for automation with the BRIO 2000-M (page 76). An electronic, pressure-dependent controller (ON/OFF) is already integrated into the BigWell 90/53 AUT.

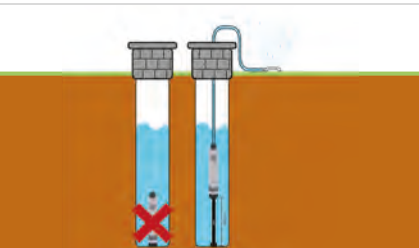
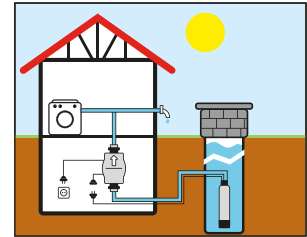

PROTECTION AGAINST SILTATION

The included, extendable base helps to minimize the risk of siltation in the pump hydraulics, ensuring the longevity and efficiency of the pump.



BigWell 90/53



BigWell 90/53 AUT

Product range

The BigWell range has an **extendable foot** that protects the pump hydraulics from silting. It is perfect for **narrow shafts from a diameter of 10 cm**.

Special features

Max. delivery rate	5,400 l/h	5,400 l/h
Max. delivery height / max. pressure	53 m / 5.3 bar	53 m / 5.3 bar
Rated power	900 watts	900 watts
Max. immersion depth	20 m	20 m
Max. contaminant particle size	≤ 1 mm / 50 g/m ³	≤ 1 mm / 50 g/m ³
Pressure connection	39.59 mm (1 1/4" inside thread)	39.59 mm (1 1/4" inside thread)
Minimum efficiency index (MEI)	≥ 0.40	≥ 0.40
Item number	30083	30084
EAN / GTIN	4011458300839	4011458103843

Delivery rate depends on the delivery height
(measured from the water surface)

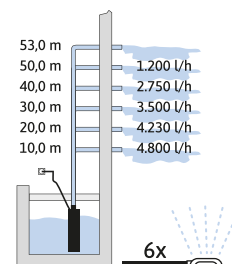
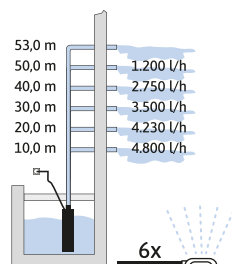



SUITABLE FOR
CLEAR WATER



SUITABLE FOR
IRRIGATION



SUITABLE FOR
DOMESTIC WATER



SUBGARDEN 6000 AUT

- » This special development combines submersible pressure and surface pump in one device
- » Dry installation possible via suction fitting
- » Wet installation possible with a floating suction in cisterns and wells
- » Ideal for fully automatic watering due to Auto ON / OFF function
- » Perfectly suited for operation with watering computer
- » Including dry-running protection and an integrated filter grille on the intake side
- » Forced motor cooling for flat water operation
- » Optimal helper for the use of natural water resources
- » With a high quality stainless steel pump and motor housing

WATERING CISTERN PUMPS

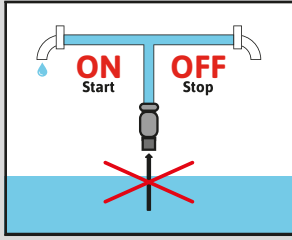

FULLY AUTOMATIC ON / OFF FUNCTION

The pump starts immediately when water is drawn off and stops immediately after stopping. In addition, the integrated dry-running protection prevents damage to the pump in the event of a lack of water).

FLOATING WATER EXTRACTION ALSO POSSIBLE

Due to the direct suction connection (Art.Nr. 31018, P.75), floating water extraction can take place from rainwater cisterns or similar containers so that only clear water is taken from below the water surface.

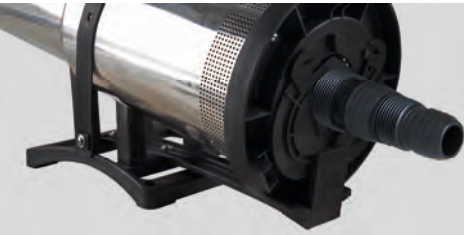
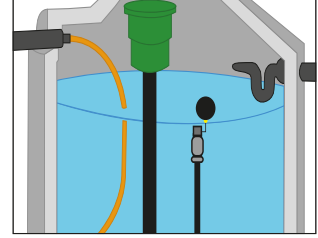

ALL IN ONE

This pump combines a submersible pressure pump and a surface pump in one unit, so the versatile use of natural and free water resources is no problem.

Product range



SubGarden 6000 AUT

Special features

- Submersible pressure and surface pump in one
- Ideal for fully automatic watering
- Extremely powerful 4-stage pump hydraulics

Max. delivery rate 6,000 l/h

Max. delivery height / max. pressure 43 m / 4.3 bar

Rated power 1,200 watts

Pressure connection 41.91 mm (1 1/4" outside thread)

Suction connection 47.80 mm (1 1/2" outside thread)

Pump housing Stainless steel

Max. contaminant particle size 1 mm

Max. liquid temperature 35°C

Max. immersion depth 12 m

Max. cable length 15 m / H07RN8-F

Item number 30137

EAN / GTIN 4011458301379

Delivery rate depends on the delivery height
(measured from the water surface)

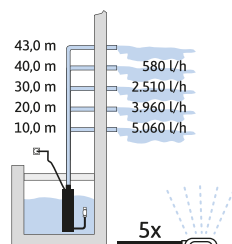

WATERING GARDEN PUMPS



SUITABLE FOR
CLEAR WATER



SUITABLE FOR
DRAINAGE



SUITABLE FOR
IRRIGATION



PLASTIC GARDEN PUMPS GPS & GPK

- » Ideal for watering your garden
- » Very light and therefore perfect for mobile use
- » Rustproof thanks to glass fibre-reinforced plastic pump housing
- » Jet hydraulic system, self-priming up to 7 m
- » Maximum suction height of 9 m
- » Convenient thanks to ergonomic handle

WATERING GARDEN PUMPS



PLASTIC PUMP HOUSING

Extremely light garden pump made of glass fibre-reinforced plastic.

PRESSURE CONNECTION

Perfect for attaching a quick coupling connection.



COMPREHENSIVE ACCESSORIES

GPS 3200 Plus including complete watering kit comprising a suction hose set (4 m), watering hose (20 m) and a 4-piece connection and watering set.

Product range



GPS 3200 Plus



GPK 3600

The pump housing in this range is made of **glass-fibre reinforced plastic** and is therefore extremely robust.

Special features

- Including complete watering kit
- With stable metal base plate

- Ideal for mobile use thanks to its low weight

Max. delivery rate	3,200 l/h	3,600 l/h
Max. delivery height / max. pressure	42 m / 4.2 bar	40 m / 4.0 bar
Rated power	650 watts	650 watts
Weight (net)	approx 9.8 kg (incl. set)	approx. 5.6 kg
Pump housing	Plastic	Plastic
Pressure connection	33.25 mm (1" outside thread)	33.25 mm (1" outside thread)
Suction connection	33.25 mm (1" outside thread)	33.25 mm (1" outside thread)
Item number	30172	30147
EAN / GTIN	4011458301720	4011458301478

Delivery rate depends on the delivery height
(measured from the water surface)

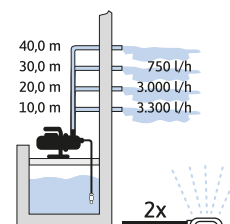
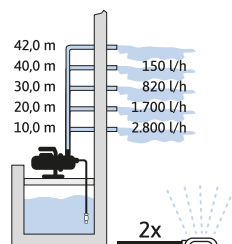

WATERING GARDEN PUMPS

SUITABLE FOR
CLEAR WATER



SUITABLE FOR
DRAINAGE



SUITABLE FOR
IRRIGATION



CAST IRON GARDEN PUMPS GARTEN JET RANGE

- » Ideal for watering your garden
- » Very smooth running due to robust cast iron pump housing
- » Jet hydraulic system, self-priming up to 7 m
- » Maximum suction height of 9 m
- » All T.I.P. garden pumps are perfectly suited for automation
- » Convenient thanks to ergonomic handle

WATERING GARDEN PUMPS



ERGONOMIC CARRYING HANDLE

Sturdy carrying handle makes this pump perfect for mobile use as a watering device.

ROBUST PUMP HOUSING

Large-capacity pump housing made of robust, unbreakable cast iron with professional performance.

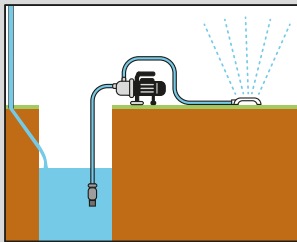

JET PUMP HYDRAULICS

All surface pumps with jet hydraulic systems have a suction height of 9 m in a completely vented system. (self-priming height max. 7 m)

Product range



Garten Jet 750



Garten Jet 1000 Plus



Garten Jet 1200

Special features

Thanks to the **robust cast iron pump housing**, our Garten Jet range is particularly **smooth**.

Max. delivery rate	2,800 l/h	3,500 l/h	5,000 l/h
Max. delivery height / max. pressure	42 m / 4.2 bar	46 m / 4.6 bar	50 m / 5 bar
Rated power	600 watts	800 watts	1,200 watts
Weight (net)	approx. 7.9 kg	approx. 8.9 kg	approx. 15,5 kg
Pump housing	Cast iron	Cast iron	Cast iron
Pressure connection	30.93 mm (1" inside thread)	30.93 mm (1" inside thread)	30.93 mm (1" inside thread)
Suction connection	30.93 mm (1" inside thread)	30.93 mm (1" inside thread)	30.93 mm (1" inside thread)
Item number	31175	30186	31174
EAN / GTIN	4011458311750	4011458301867	4011458311743

Delivery rate depends on the delivery height
(measured from the water surface)

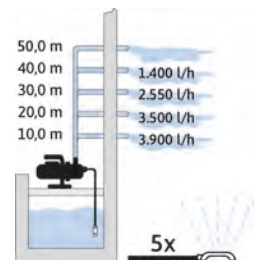
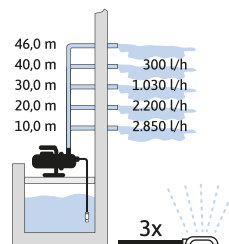
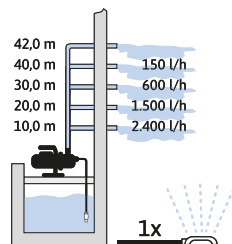

WATERING GARDEN PUMPS

SUITABLE FOR
CLEAR WATER



SUITABLE FOR
DRAINAGE



SUITABLE FOR
IRRIGATION



STAINLESS STEEL GARDEN PUMPS GP RANGE

- » Ideal for watering your garden
- » High-quality stainless steel pump housing
- » Extremely corrosion-resistant and therefore guaranteed to be rustproof
- » Ergonomically-shaped carrying handle
- » Maximum suction height for the Jet hydraulic unit of up to 9 m
- » All T.I.P. garden pumps are perfectly suited for automation

WATERING GARDEN PUMPS



HIGH-QUALITY INDUCTION MOTOR

Sturdy carrying handle makes this pump perfect for mobile use as a watering device.

STAINLESS STEEL PUMP HOUSING

Large-capacity pump housing made of robust, unbreakable cast iron with professional performance.



WEATHER-RESISTANT

All surface pumps with jet hydraulic systems have a suction height of 9 m in a completely vented system. (self-priming height max. 7 m)

Product range



Special features

• Multi-stage garden pump with 5 impellers

	GP 3000 INOX	GP 4000 INOX	GP 5000 INOX	GP 6000 INOX
Max. delivery rate	2,950 l/h	4,000 l/h	5,000 l/h	6,000 l/h
Max. delivery height / max. pressure	42 m / 4.2 bar	42 m / 4.2 bar	45 m / 4.5 bar	55 m / 5.5 bar
Rated power	550 watts	800 watts	1,200 watts	1,200 watts
Weight (net)	approx. 5.6 kg	approx. 6.9 kg	approx. 9.9 kg	approx. 10.1 kg
Pump housing	Stainless steel	Stainless steel	Stainless steel	Stainless steel
Pressure connection	30.93 mm (1" inside thread)	30.93 mm (1" inside thread)	30.93 mm (1" inside thread)	30.93 mm (1" inside thread)
Suction connection	30.93 mm (1" inside thread)	30.93 mm (1" inside thread)	30.93 mm (1" inside thread)	30.93 mm (1" inside thread)
Item number	30111	31371	31372	31373
EAN / GTIN	4011458301119	4011458313716	4011458313723	4011458313730

Delivery rate depends on the delivery height
(measured from the water surface)

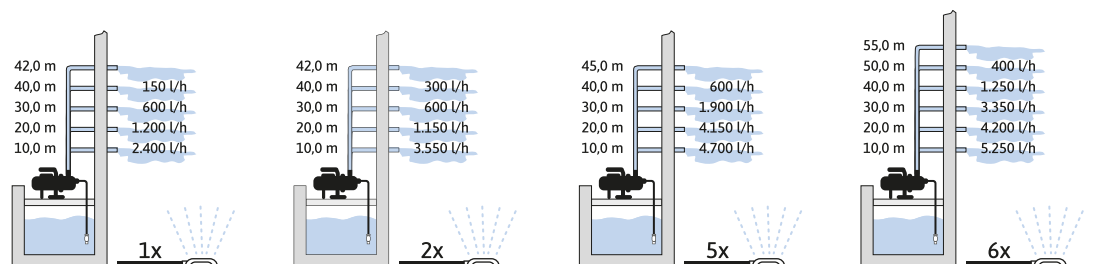

WATERING GARDEN PUMPS

SUITABLE FOR
CLEAR WATER



SUITABLE FOR
DRAINAGE



SUITABLE FOR
IRRIGATION



STAINLESS STEEL GARDEN PUMPS CLEAN JET RANGE

- » Ideal for watering your garden
- » High-quality stainless steel pump housing
- » Extremely corrosion-resistant and therefore guaranteed to be rustproof
- » Ergonomically-shaped carrying handle
- » Maximum suction height for the Jet hydraulic unit of up to 9 m
- » All T.I.P. garden pumps are perfectly suited for automation
- » Range include a suction set (4 m) with a coarse filter and a check valve

WATERING GARDEN PUMPS



METAL BASE PLATE

All Clean Jet models have an extremely solid metal base plate for extra stability.

STAINLESS STEEL PUMP HOUSING

Housing made of high-quality rustproof stainless steel.



SUCTION HOSE

All models in the Clean Jet range include a suction set (4 m) with a coarse filter and a check valve.



**Clean Jet 1000
Plus with kit**



**Clean Jet 1300
Plus with kit**

Product range

Special features

Our CleanJet series is equipped with a **sturdy metal base plate** and has a **4 m suction set**.

Max. delivery rate	3,300 l/h	4,400 l/h
Max. delivery height / max. pressure	46 m / 4.6 bar	50 m / 5.0 bar
Rated power	800 watts	1,200 watts
Weight (net)	approx. 7.1 kg	approx. 9.7 kg
Pump housing	Stainless steel	Stainless steel
Pressure connection	30.93 mm (1" inside thread)	30.93 mm (1" inside thread)
Suction connection	30.93 mm (1" inside thread)	30.93 mm (1" inside thread)
Item number	30094	30087
EAN / GTIN	4011458300945	4011458300877

Delivery rate depends on the delivery height
(measured from the water surface)

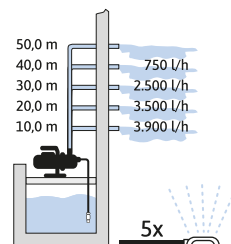
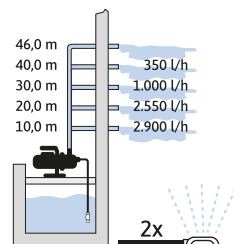

WATERING SMART GARDEN PUMPS



SUITABLE FOR
CLEAR WATER



SUITABLE FOR
DRAINAGE



SUITABLE FOR
IRRIGATION



SMART GARDEN PUMPS SMARTGARDEN RANGE

- » Powerful and self-priming jet garden pumps for efficient watering
- » Manual ON / OFF function and unlimited timer function via APP
- » Connection and control unit via WiFi possible worldwide
- » Operation of the pump also possible directly on the unit
- » LED colour indicators of the operating status as integrated function control on the switchbox
- » Integrated dry-running and blockage protection is presented in the APP on release
- » Also controllable with the aid of artificial intelligence (e.g. "Alexa", Google Assistant, etc.)
- » Easily accessible, integrated pre-filter

WATERING SMART GARDEN PUMPS



CONTROL VIA T.I.P. APP

Control your pump conveniently and comfortably from anywhere using the feature-rich app. This means that you can operate your garden pump in a use-oriented and energy-saving manner.

POWER CONSUMPTION DISPLAY

In the APP, you can easily read off the exact power consumption. This means that you always have the efficient and optimal watering of your garden in view.

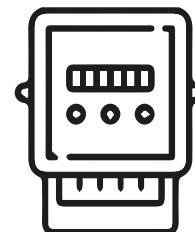

COMPATIBILITY

You can access compatible devices from other manufacturers via the app. Further possibilities arise through the connection to established cloud platforms such as Google Assistant or Amazon "Alexa".

Product range



**SmartGarden
3500 KF**



**SmartGarden
5000 KF**

Special features

The SmartGarden range has an **integrated function control** and can be controlled via an app or other smart devices such as an "Alexa"

Max. delivery rate	3,300 l/h	5,000 l/h
Max. delivery height / max. pressure	46 m / 4.6 bar	45 m / 4.5 bar
Rated power	800 watts	1,200 watts
Max. suction height	9 m	9 m
Pump housing	Plastic	Plastic
Pressure connection	30.93 mm (1" inside thread)	30.93 mm (1" inside thread)
Suction connection	39.59 mm (1 1/4" inside thread)	39.59 mm (1 1/4" inside thread)
Max. liquid temperature	35°C	35°C
Max. number of sprinklers.	2	5
Max. cable length	1.5 m / H07RN-F	1.5 m / H07RN-F
Item number	30151	30152
EAN / GTIN	4011458103188	4011458103195

Delivery rate depends on the delivery height
(measured from the water surface)

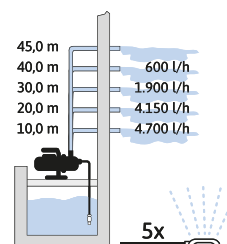
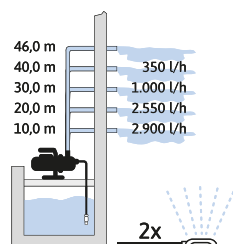

WATERING AUTOMATIC DOMESTIC WATER SYSTEMS



SUITABLE FOR
CLEAR WATER



SUITABLE FOR
IRRIGATION



SUITABLE FOR
DOMESTIC WATER



AUTOMATIC DOMESTIC WATER SYSTEMS HWA RANGE

- » Ideal for automatic water supply
- » Just like a water supply from the mains thanks to an automatic switch-on and switch-off function
- » The electronic control system protects against damage from running when there is too little water (dry running protection)
- » Ergonomically-shaped carrying handle
- » Jet hydraulic system, self-priming up to 7 m
- » Maximum suction height of 9 m

WATERING AUTOMATIC DOMESTIC WATER SYSTEMS



ELECTRONIC PUMP CONTROLLER

Thanks to the pre-installed BRIO 2000-M, the automatic domestic water system switches on automatically when the minimum pressure is reached. After the consumer (tap) is closed, it switches off automatically.

DRY RUNNING PROTECTION

The electronic pump controller protects the automatic domestic water system against damage caused by dry running.

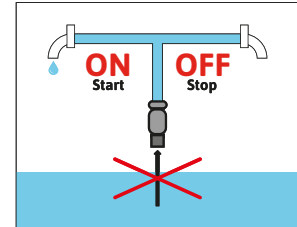

WEATHER-RESISTANT

Thanks to the high-quality materials installed, all T.I.P. garden pumps can remain outside even in bad weather. The devices only have to be protected from freezing.



**HWA 3000
INOX**



**HWA 4400
INOX Plus**

Product range

Special features

The pumps in this range have a **stainless steel housing** and are equipped with a **stable base plate**.

Max. delivery rate	2,800 l/h	4,250 l/h
Max. delivery height / max. pressure	42 m / 4.2 bar	44 m / 4.4 bar
Rated power	550 watts	900 watts
Weight (net)	approx. 6.7 kg	approx. 8.8 kg
Pump housing	Stainless steel	Stainless steel
Pressure connection	33.25 mm (1" outside thread)	33.25 mm (1" outside thread)
Suction connection	30.93 mm (1" inside thread)	30.93 mm (1" inside thread)
Item number	31142	31192
EAN / GTIN	4011458311422	4011458311927

Delivery rate depends on the delivery height
(measured from the water surface)

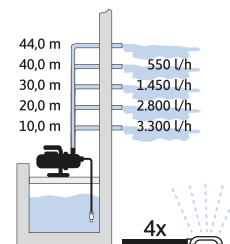
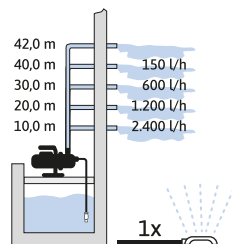



PUMPS FOR DOMESTIC WATER SUPPLY

Our extensive range for automatic domestic water supply offers the right product for every purpose.

- *Using service water from containers, cisterns and wells*
- *Pumping and transferring at high pressure*
- *Operating watering systems efficiently*
- *Pumping water at a constant pressure*
- *Economical use of grey water*

Our pumps are made of high quality materials, have energy-efficient copper coils and thermal motor protection.



PRE-FILTERS

Some of our booster sets come with equipped a pre-filter as standard. Pre-filters minimise wear and prolong the service life of the pump, as they are effective for filtering sand and solids out of the liquid. Key advantage: The filter element is easy to clean, so it can be re-used.



DRY RUNNING PROTECTION (TLS)

Dry running protection protects pumps from damage due to the hydraulic parts overheating, which may occur if operated when there is a lack of water. This is known as dry running and is often the cause of significant damage to the device. Dry running protection prevents this risk consistently, as it causes the pump to switch off in good time.



PUMP HOUSING

Our pump housings are available in different high-quality materials. The pump that is suitable can be determined using the performance required or the material. Depending on the requirements and the application, you can choose between light glass fibre-reinforced plastic, robust and smooth-running cast iron or rustproof, high-quality stainless steel.



DIAPHRAGMS

Each booster set is equipped with a relief diaphragm inside the pressure vessel, into which the pressurised water flows. The water therefore only comes into contact with the diaphragm. This is why we only use high-quality and odour-free EPDM diaphragms that are made in Europe.



PRESSURE VESSELS

The pressure vessel acts as a storage and relief medium that enables a permanent water supply with even pressure. It is therefore important to select the correct vessel size for the corresponding application. Our models have compact 18 or 22 l to energy-saving 50 l pressure vessels made of various materials.

DOMESTIC WATER SUPPLY BOOSTER SETS



SUITABLE FOR
CLEAR WATER



SUITABLE FOR
IRRIGATION



SUITABLE FOR
DOMESTIC WATER



BOOSTER SET CAST IRON

- » Pumping water at a constant pressure thanks to pressure tanks
- » Boosting pressure in domestic water systems with service water
- » Extremely smooth and quiet models with cast iron pump housings
- » Painted steel pressure vessel with high-quality EPDM diaphragm

DOMESTIC WATER SUPPLY BOOSTER SETS



ROBUST PUMP HOUSING

Very smooth running due to robust cast iron pump housing.

HIGH QUALITY EPDM DIAPHRAGM

All T.I.P. domestic waterworks are equipped with high-quality, odour-free EPDM diaphragms that are made in Europe.

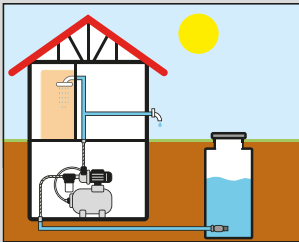

AUTOMATIC DOMESTIC WATER SUPPLY

All T.I.P. models are ideally suited for automatic domestic water supplies with service water. You can therefore save precious drinking water.

Product range



HWW
900/25 Plus



HWW
G-1000 Plus



HWW
1200/25

Special features

- Robust and smooth cast iron pump housing
- 18 l steel pressure vessel

- Robust and smooth cast iron pump housing
- 22 l steel pressure vessel

- Robust and smooth cast iron pump housing
- 22 l steel pressure vessel

Max. delivery rate

2,800 l/h

3,500 l/h

5,000 l/h

Max. delivery height / max. pressure

42 m / 4.2 bar

46 m / 4.6 bar

50 m / 5.0 bar

Rated power

600 watts

800 watts

1,200 watts

Weight (net)

approx. 12.7 kg

approx. 14.3 kg

approx. 21.2 kg

Pump housing

Cast iron

Cast iron

Cast iron

Pressure connection

30.93 mm
(1" inside thread)

30.93 mm
(1" inside thread)

30.93 mm
(1" inside thread)

Suction connection

30.93 mm
(1" inside thread)

30.93 mm
(1" inside thread)

30.93 mm
(1" inside thread)

Pressure vessels

18 l / steel

22 l / steel

22 l / steel

Item number

31300

30187

31111

EAN / GTIN

4011458313006

4011458301874

4011458311118

Delivery rate depends on the delivery height
(measured from the water surface)

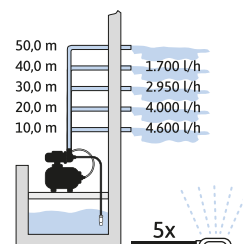
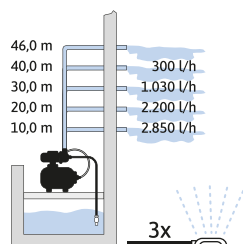
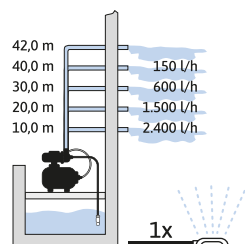

DOMESTIC WATER SUPPLY BOOSTER SETS



SUITABLE FOR
CLEAR WATER



SUITABLE FOR
IRRIGATION



SUITABLE FOR
DOMESTIC WATER



BOOSTER SET STAINLESS STEEL

- » Pumping water at a constant pressure thanks to pressure tanks
- » Boosting pressure in domestic water systems with service water
- » High-quality stainless steel pump housing
- » Various models equipped with dry running protection or pre-filters
- » With painted steel pressure vessel and high-quality EPDM diaphragm
- » Ready-to-install pressure switch with approx. 1.6 bar cut-in and 3 bar cut-out pressure

DOMESTIC WATER SUPPLY BOOSTER SETS

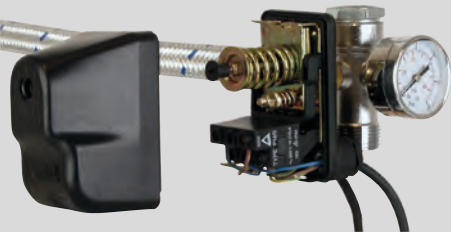

PRESSURE SWITCH & PRESSURE GAUGE

The cut-in and cut-out pressure can be set separately and are viewable on the pressure gauge.

PRE-FILTERS

The pre-filter is equipped with a washable filter element for sand and solids, and prolongs the pump's service life.

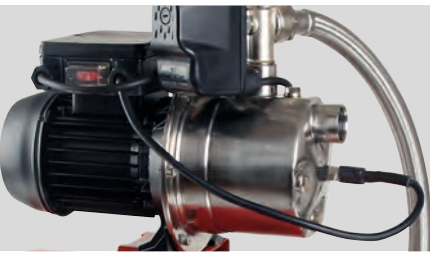

DRY RUNNING PROTECTION (TLS)

Built-in dry running protection prevents damage to the hydraulic unit due to operation when there is too little water.

Included with the HWW 1000/25 Plus TLS and HWW 1300/25 Plus TLS.

Product range

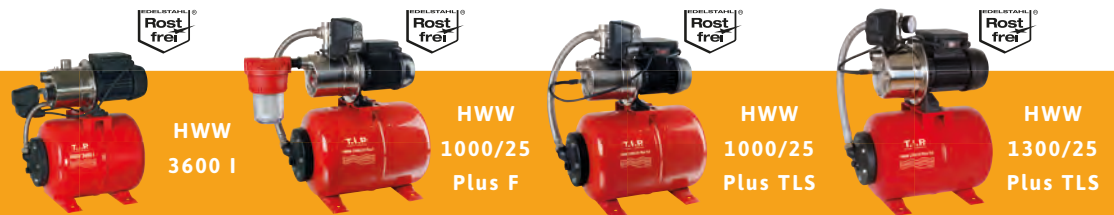

Special features

- 18 l steel pressure vessel with a compact design
- High-quality pre-filter
- 22 l steel pressure vessel
- Dry running protection
- 22 l steel pressure vessel
- Dry running protection
- 22 l steel pressure vessel

Max. delivery rate	3,600 l/h	3,300 l/h	3,300 l/h	4,350 l/h
Max. delivery height / max. pressure	40 m / 4.0 bar	46 m / 4.6 bar	46 m / 4.6 bar	50 m / 5.0 bar
Rated power	650 watts	800 watts	800 watts	1,200 watts
Weight (net)	approx. 10.7 kg	approx. 12.7 kg	approx. 12.2 kg	approx. 14.4 kg
Pump housing	Stainless steel	Stainless steel	Stainless steel	Stainless steel
Pressure connection	30.93 mm (1" inside thread)	30.93 mm (1" inside thread)	30.93 mm (1" inside thread)	30.93 mm (1" inside thread)
Suction connection	30.93 mm (1" inside thread)	30.93 mm (1" inside thread)	30.93 mm (1" inside thread)	30.93 mm (1" inside thread)
Pressure vessels	18 l / steel	22 l / steel	22 l / steel	22 l / steel
Item number	31188	31144	31145	31158
EAN / GTIN	4011458311880	4011458311446	4011458311453	4011458311583

Delivery rate depends on the delivery height
(measured from the water surface)

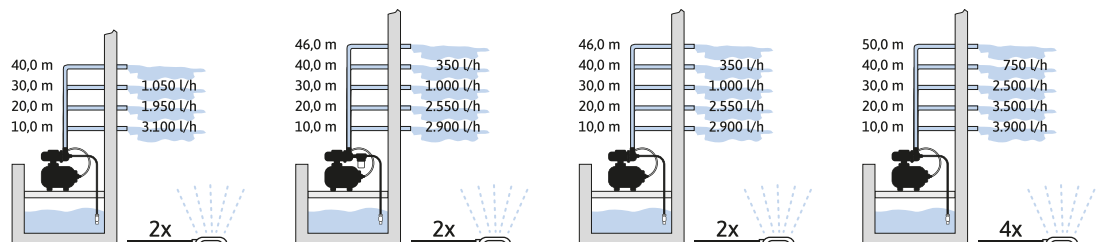

DOMESTIC WATER SUPPLY BOOSTER SETS



SUITABLE FOR
CLEAR WATER



SUITABLE FOR
IRRIGATION



SUITABLE FOR
DOMESTIC WATER



BOOSTER SET COMPLETE STAINLESS STEEL

- » Pumping water at a constant pressure thanks to pressure tanks
- » Boosting pressure in domestic water systems with service water
- » Pump housing and pressure vessel made of high quality stainless steel with a wall thickness of at least 1 mm
- » Extremely corrosion-resistant and therefore guaranteed to be rustproof
- » Ready-to-install pressure switch with approx. 1.6 bar cut-in and 3 bar cut-out pressure
- » All models with a high-quality EPDM diaphragm and some models are also equipped with a large-capacity pre-filter

DOMESTIC WATER SUPPLY BOOSTER SETS



HIGH QUALITY PUMP & MOTOR

Pump housing made of high-quality stainless steel and maintenance-free motor with thermal overload protection.

PRESSURE VESSELS

18 or 22l pressure vessel made of high-quality stainless steel. (AISI 304)



SEPARATE FILTER

You can equip every domestic waterworks with an additional pre-filter to extend the service life of the pump. A pre-filter is already included in the scope of delivery of the HWW INOX 1300 Plus F.



**HWW 3000
INOX**



**HWW 4400
INOX Plus**



**HWW 4500
INOX**



**HWW INOX
1300 Plus F**

Product range

Special features

- 18 l stainless steel pressure vessel
- 22 l stainless steel pressure vessel
- 22 l stainless steel pressure vessel
- Including pre-filter
- 22 l stainless steel pressure vessel

Max. delivery rate

2,950 l/h

4,350 l/h

4,350 l/h

4,350 l/h

Max. delivery height / max. pressure

42 m / 4.2 bar

45 m / 4.5 bar

50 m / 5.0 bar

50 m / 5.0 bar

Rated power

550 watts

1,000 watts

1,200 watts

1,200 watts

Weight (net)

approx. 9.9 kg

approx. 12.7 kg

approx. 14.4 kg

approx. 15.2 kg

Pump housing

Stainless steel

Stainless steel

Stainless steel

Stainless steel

Pressure connection

30.93 mm
(1" inside thread)

30.93 mm
(1" inside thread)

30.93 mm
(1" inside thread)

30.93 mm
(1" inside thread)

Suction connection

30.93 mm
(1" inside thread)

30.93 mm
(1" inside thread)

30.93 mm
(1" inside thread)

30.93 mm
(1" inside thread)

Pressure vessels

18 l / stainless steel

22 l / stainless steel

22 l / stainless steel

22 l / stainless steel

Item number

31143

31167

31140

31155

EAN / GTIN

4011458311439

4011458311675

4011458311408

4011458311552

**Delivery rate depends on the
delivery height**
(measured from the water surface)

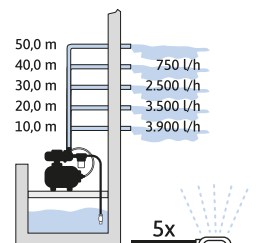
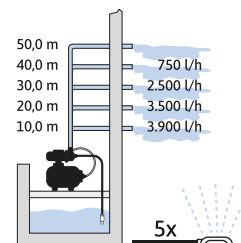
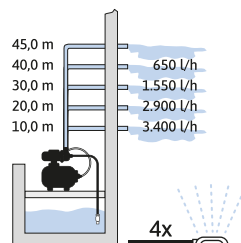
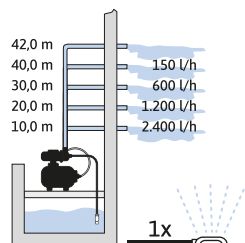

DOMESTIC WATER SUPPLY BOOSTER SETS



SUITABLE FOR
CLEAR WATER



SUITABLE FOR
IRRIGATION



SUITABLE FOR
DOMESTIC WATER



BOOSTER SET 50 LITRE PRESSURE VESSEL

- » Pumping water at a constant pressure thanks to pressure tanks
- » Boosting pressure in domestic water systems with service water
- » Powerful jet pump, self-priming up to 7 m
- » Larger pressure vessels reduce the frequency of starts and increase efficiency
- » This reduces energy consumption and noise emissions significantly
- » Pressure vessels are equipped with a high-quality EPDM diaphragm
- » Maximum suction height of 9 m in a completely vented system

DOMESTIC WATER SUPPLY BOOSTER SETS



HIGH-QUALITY PUMP HOUSING

High-quality pump housing made of glass-fibre reinforced plastic or stainless steel.

50 LITRE PRESSURE VESSEL

The increased capacity reduces the frequency of starts and energy consumption.



DRY RUNNING PROTECTION (TLS)

Built-in dry running protection prevents damage due to operation when there is too little water. Included with the HWW 1300/50 Plus TLS.



HWW K-1000/50 Plus



HWW 1300/50 Plus TLS

Product range

This range is equipped with a 50 l steel pressure vessel.

Special features

	<ul style="list-style-type: none"> Robust glass fibre-reinforced plastic pump housing 	<ul style="list-style-type: none"> Integrated dry running protection Stainless steel pump housing
Max. delivery rate	3,500 l/h	4,200 l/h
Max. delivery height / max. pressure	46 m / 4.6 bar	50 m / 5.0 bar
Rated power	800 watts	1,200 watts
Weight (net)	approx. 15.2 kg	approx. 17.6 kg
Pump housing	Plastic	Stainless steel
Pressure connection	33.25 mm (1" outside thread)	30.93 mm (1" inside thread)
Suction connection	33.25 mm (1" outside thread)	30.93 mm (1" inside thread)
Pressure vessels	50 l / steel	50 l / steel
Item number	30189	31311
EAN / GTIN	4011458301898	4011458313112

Delivery rate depends on the delivery height
(measured from the water surface)

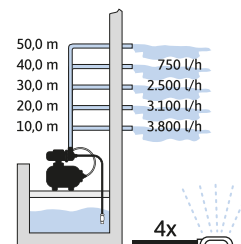
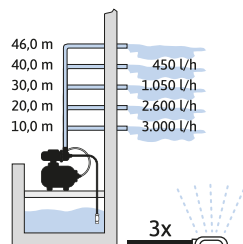



PUMPS FOR SPECIAL APPLICATIONS

Our range of special pumps provides suitable products for the widest range of applications.

- *Petrol engine pumps as the ideal solution for pumping water on sites remote from any mains connection*
- *Special peripheral pumps for pumping sandy water*
- *Heating circulation pumps to adjust the power consumption in the pipe network*



SOLAR POWERED IRRIGATION SYSTEM

Whether on the balcony, in the small city garden or on your terrace, with our products for adequate watering you can live out your gardening passion even in the smallest areas. The SBS 36 is ideal for watering plants during longer absences. The complete set is ideally suited for the automatic and mains-independent water supply of your plants.



MOTORISED WATERING AND DRAINAGE PUMPS

Electric pumps cannot be used at some locations. Petrol engine pumps do not rely on mains power and are therefore the ideal solution here. They have a high maximum delivery rate that enables them to transport large amounts of liquid quickly.



SURFACE PUMPS FOR SANDY WATER

Garden pumps are characterised by their wide range of applications, but are not only suitable for pumping clear, non-sandy water. With the peripheral pump series with brass impeller, water containing sand can be pumped without any problems. It should be noted that these pumps are not self-priming.

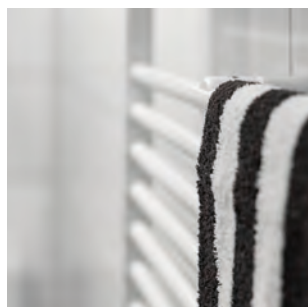

HEATING CIRCULATION PUMPS

Heating circulation pumps adjust their power consumption exactly to the pressure in the pipe network. The HZP range has a permanent magnet motor and differential pressure regulations that enables the pump performance to be adjusted continuously to the system conditions.

SPECIAL APPLICATIONS
SOLAR POWERED IRRIGATION SYSTEM



SBS 36

- » Ideal for independent watering of plants during longer absences
- » No power supply necessary thanks to solar/battery operation
- » Automatic watering 2x a day
- » No dry running of the pump thanks to water level sensor
- » Individually adjustable watering time
- » Complete set including all necessary accessories
- » Suitable for up to 15 plants

SPECIAL APPLICATIONS

SOLAR POWERED IRRIGATION SYSTEM



INDEPENDENT SUPPLY

Ideally suited to watering your potted plants, vegetable beds or window boxes automatically and without a mains water connection.

HOLIDAY WATERING

Independent watering of plants during longer absences.



COMPLETE SET

The SBS 36 is supplied as a complete set with all necessary accessories.



Product range

SBS 36

Special features

- Individually adjustable watering time
- Suitable for up to 15 plants

Max. rated power of solar panel	0.7 watts
Max. delivery rate	36 l/h
Max. delivery height	3 m
Battery capacity	2,000 mAh (3.7 V Li-Ion)
Hose length	7 m
Weight	1.2 kg
Item number	30338
EAN / GTIN	4011458303380

SPECIAL APPLICATIONS
MOTORISED WATERING AND DRAINAGE PUMPS

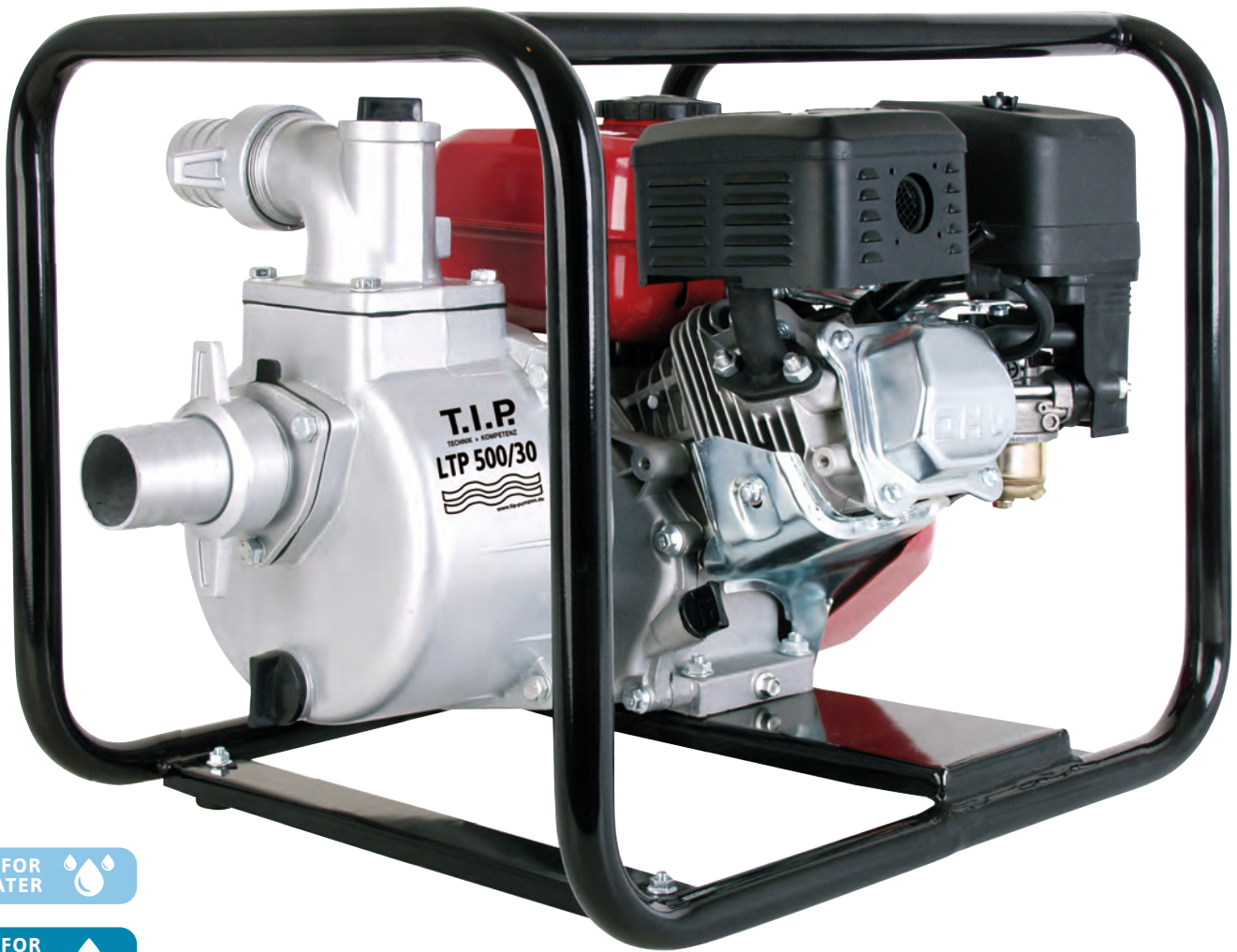

SUITABLE FOR
CLEAR WATER



SUITABLE FOR
DRAINAGE



SUITABLE FOR
IRRIGATION



LTP RANGE

- » Perfect for watering and drainage on allotments, at weekend cottages, in agriculture or on building sites
- » Operation independent of the mains
- » Starter rope for easy starting
- » Cast aluminium pump housing
- » Robust, air-cooled 4-stroke petrol engines with low-oil protection
- » Equipped with hose connection accessories

SPECIAL APPLICATIONS MOTORISED WATERING AND DRAINAGE PUMPS



FIRM STAND

The LTP 250/25 is mounted on a sturdy tubular steel base frame.

MOTOR

The models in the LTP series are equipped with a robust, air-cooled 4-stroke petrol engine.

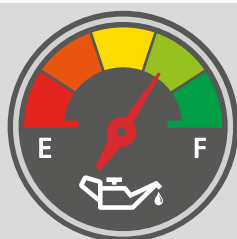

SAFETY & DURABILITY

Low oil protection: This technology protects against damage due to low engine oil level.

Product range



LTP 250/25



LTP 500/30

Our LTP range has an **integrated check valve** and **low-oil protection**.

Special features

- Mounted on a stable steel tube base frame

- Mounted in a stable steel tube frame

Max. delivery rate

15,000 l/h

30,000 l/h

Max. delivery height / max. pressure

25 m / 2.5 bar

30 m / 3.0 bar

Suction height

6 m

6 m

Max. power

1.8 kW (2.5 HP)

3.85 kW (5.2 HP)

Suction and pressure connection

47.80 mm (1 1/2" outside thread), 40 mm

59.61 mm (2" outside thread), 50 mm

Cubic capacity

127 ccm

196 ccm

Tank volume

1.6 l

3.5 l

Fuel

Unleaded petrol / E10

Unleaded petrol / E10

Item number

30188

30197

EAN / GTIN

4011458301881

4011458301973

Delivery rate depends on the delivery height
(measured from the water surface)

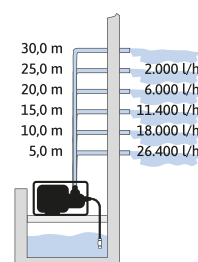
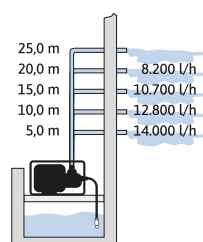

SPECIAL APPLICATIONS
SURFACE PUMPS FOR SANDY WATER



SUITABLE FOR
CLEAR WATER



SUITABLE FOR
DRAINAGE



SUITABLE FOR
IRRIGATION



GPP

- » Suitable for watering and drainage
- » Robust pumps for pumping sandy water
- » Housing made of robust cast iron with high-quality brass impeller and stainless steel inlay

SPECIAL APPLICATIONS SURFACE PUMPS FOR SANDY WATER

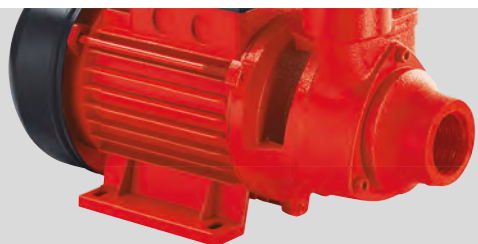

EXTREME SAND RESISTANCE

Even suitable for sandy water, with a robust cast iron pump housing and peripheral impeller pump hydraulics.

PROTECTION AGAINST SAND

The high-quality stainless steel inlay in this pump makes the GPP 2100 M particularly resistant to sand.



HIGH-QUALITY EQUIPMENT

The cast iron pump housing with brass impeller and stainless steel inlay guarantees reliability and a long service life.



Product range

GPP 2100 M

Special features

- Surface pump for sandy water
- With brass impeller and stainless steel inlay

Max. delivery rate

2,100 l/h

Max. delivery height / max. pressure

35 m / 3.5 bar

Rated power

550 watts

Weight (net)

approx. 5.4 kg

Max. suction height

8 m (not self-priming)

Suction and pressure connection

30.93 mm (1" inside thread)

Pump housing

Cast iron

Item number

30183

EAN / GTIN

4011458301836

Delivery rate depends on the delivery height

(measured from the water surface)

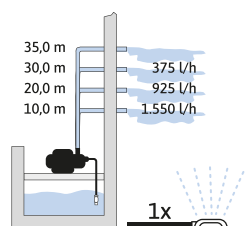



HZP RANGE

- » For efficient circulation of the heating circuit
- » Highly-efficient pump with automatic adjustment to the optimum standard characteristic curve
- » In addition to the automatic range, further control characteristic curves and fixed speed stages can be selected
- » Very low energy efficiency index (EEI) < 0.20
- » LED display with indication of the current power consumption
- » System plug for easy electrical connection
- » Including custom-fit insulation shell and two high-quality seals

SPECIAL APPLICATIONS HEATING CIRCULATION PUMPS



CLEAR CONTROL PANEL

Different operating modes can be easily selected in the clear display. The respective operating status and the corresponding power consumption of the pump are permanently visible.

EASY TO INSTALL

With system plug for easy electrical connection. The electronic controller does not have to be opened in order to connect the power cable.



ACCESSORIES

Two high-quality seals and a custom-fit insulation shell are supplied as standard and these prevent heat loss.

Product range



HWP 25-40-180 ECO



HWP 25-60-180 ECO

Max. delivery rate 2,610 l/h

3,600 l/h

Max. delivery height 4 m

6 m

Rated power 5 - 22 watts

5 - 45 watts

Max. operating pressure 10 bar

10 bar

Energy efficiency index (EEI) < 0.20

< 0.20

Connection 47.80 mm (1½" outside thread)

47.80 mm (1½" outside thread)

Weight (net) approx. 2.3 kg

approx. 2.3 kg

Item number 31421

31422

EAN / GTIN 4011458314218

4011458314225

Performance charts

HWP 25-40-180 ECO

HWP 25-60-180 ECO

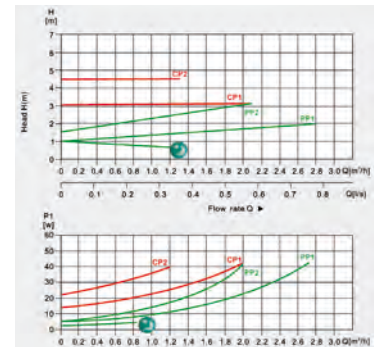
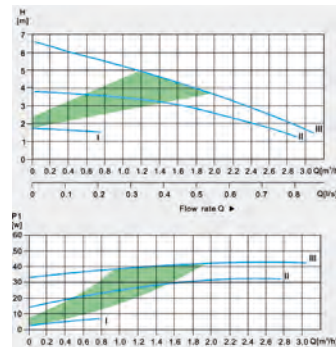
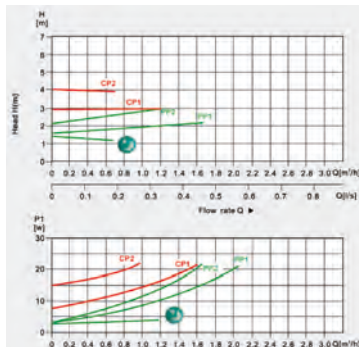
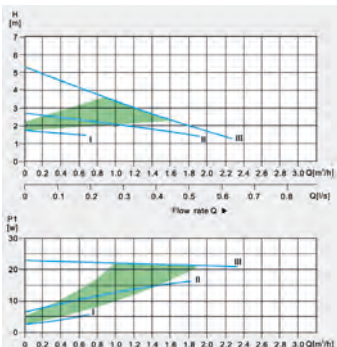

MISCELLANEOUS



BRIO 2000-M ELECTRONIC CONTROL SYSTEM

Enables you to automate any type of pressure pump with more than 1.5 bar thanks to easy installation. Protects against damage caused by dry running. The pump switches on automatically when the minimum pressure is reached. After the consumer (tap) is closed, it switches off automatically. Including pressure gauge and double nipple.

Maximum liquid temperature: 55 °C
Cut-in pressure: 1.0 - 3.5 bar
Operating pressure: max. 10.0 bar

Inlet	Outlet	Item no.	EAN / GTIN
33.25 mm (1" outside thread) / 30.93 mm (1" inside thread)	33.25 mm (1" outside thread)	30241	4011458302413



TLS 100 E DRY RUNNING PROTECTION

Can be retrofitted to all domestic waterworks and garden pumps without problems. Protects the device against damage caused by insufficient water. With optical function and fault indicator.

Inlet	Outlet	Item no.	EAN / GTIN
33.25 mm (1" outside thread)	30.93 mm (1" inside thread)	30915	4011458309153



TPT 20 (UNIVERSAL) MOUNTING SYSTEM

Mounting system with a wide range of applications for all submersible, submersible pressure and deep well pumps. More installation flexibility thanks to horizontal or vertical pump positioning. Increased pump stability and reliability by installing the mounting system on the edge of the cistern or the well. As a wall bracket, it is an ideal storage location for the pump, e.g. in frosty weather or out of season.

Item no.	EAN / GTIN
30947	4011458309474



LOWERING ROPE

Heavy-duty nylon lowering rope. Suitable for fastening to submersible pumps for lowering them into shafts.

Length	Item no.	EAN / GTIN
21 m	30912	4011458309122

FILTER



G5 & G7 UNIVERSAL WATER FILTERS

Pre-filters for garden pumps and domestic waterworks. Prolongs the pump's service life. 3-piece, with threaded ring for the filter glass. Brass vent screw and high-quality 30.93 mm (1" inside thread) brass connection thread, including washable filter cartridge against sand and solids. Transparent filter bowl made of high-quality plastic. Maximum flow rate: 7,000 l/h

	Item	Size	Item no.	EAN / GTIN
①	Water filter G 5	127 mm (5")	31052	4011458310524
②	Water filter G 7	178 mm (7")	31058	4011458310586



G5 & G7 DISPOSABLE AND REUSABLE FILTER ELEMENTS

Disposable thread filter element and washable plastic filter element against sand and solids.

	Filter element	Filter effect	Item no.	EAN / GTIN
①	Disposable for G 5 filter	80 microns	31054	4011458310548
②	Disposable for G 7 filter	80 microns	31056	4011458310562
③	Reusable for G 5 filter	250 microns	31053	4011458310531
④	Reusable for G 7 filter	250 microns	31057	4011458310579



HOSES



DRAINAGE HOSE

10 m drainage hose, infinitely extendible. Suitable for connection to submersible, submersible pressure and garden pumps, as it is pressure-resistant to 6.0 bar. To transfer clear and waste water from swimming pools, pools, ponds, cisterns, etc.

Length	Item no.	EAN / GTIN
10 m	31008	4011458310081

Connection options

30,93 mm (1" IG)	33,25 mm (1" AG)	39,59 mm (1 1/4" IG)	41,91 mm (1 1/4" AG)
------------------	------------------	----------------------	----------------------



TEXTILE HOSE WITH C-STORZ COUPLING

This textile hose with a double-twisted polyester thread sleeve can be used anywhere where water needs to be pumped. A quick connection or release is possible via the pre-installed C-Storz couplings. The hose is able to resist a maximum working pressure of 10.0 bar.

Size / Length	Item no.	EAN / GTIN
2" / 15 m	31090	4011458310906



HOSES



PLASTIC SUCTION SET

Plastic suction hose set. Complete with coarse suction filter and integrated check valve. For garden pumps, domestic waterworks and automatic domestic water systems. Designed especially for use with starter garden pumps.

Length	Item no.	EAN / GTIN
4 m	31009	4011458310098
7 m	31012	4011458310128

Connection options

30,93 mm (1" IG)	33,25 mm (1" AG)	39,59 mm (1 ¼" IG)	41,91 mm (1 ¼" AG)
------------------	------------------	--------------------	--------------------



BRASS SUCTION SET (1")

For suction and pressure purposes up to an operating pressure of 6.0 bar and 60 percent vacuum. Made of kink- and abrasion-resistant material. Concealed hard PVC spiral; including Brass foot valve with stainless steel coarse filter and brass thread for pump connection. Suitable for all garden pumps, automatic domestic water systems and domestic waterworks.

Length	Item no.	EAN / GTIN
4 m	30906	4011458309061
7 m	30907	4011458309078

Connection options

30,93 mm (1" IG)	33,25 mm (1" AG)
------------------	------------------



HOSES



BRASS SUCTION SET (1½")

For suction and pressure purposes up to an operating pressure of 6.0 bar and 60 percent vacuum. Made of kink- and abrasion-resistant material. Concealed hard PVC spiral; including Brass foot valve with stainless steel coarse filter and brass thread for pump connection. Suitable for petrol engine pumps, all garden pumps, automatic domestic water systems and domestic waterworks.

Length	Item no.	EAN / GTIN
7 m	30916	4011458309160

Connection options

45,48 mm (1½" IG)	47,80 mm (1½" AG)
-------------------	-------------------



ALL-PURPOSE SPIRAL HOSE

Flexible, UV-resistant spiral hose made of plastic-coated PVC with a spiral made of hard PVC. For filling and emptying garden ponds and pools. Suitable for suction systems, e.g. air, dust (vacuum cleaner) and wood shavings. Can be used from -15 °C to +60 °C. Anti-algae, cadmi-um-free, barium-free and phthalate-free.

Size	Length	Item no.	EAN / GTIN
Ø 20 mm	5 m	31014	4011458310142
Ø 25 mm	5 m	31015	4011458310159
Ø 32 mm	5 m	31016	4011458310166

HOSES



SET FOR FLOATING SUCTION

High-quality, very flexible pressure- and suction-proof hose with ball float. For special applications such as floating removal of rain water from wells, cisterns and containers.

Length	Item no.	EAN / GTIN
2 m	31018	4011458310173

Connection options

30,93 mm (1" IG)	33,25 mm (1" AG)
------------------	------------------



BALL FLOAT WITH FOOT VALVE

For the floating removal of rainwater from cisterns, containers, wells or similar prevents dirt particles such as sand being sucked in (from the ground). Suitable for suction hoses with 25 mm inner diameter (1").

Item no.	EAN / GTIN
30914	4011458309146

Connection options

25 mm (1")



PRESSURE SPIRAL HOSE (1¼")

5 metre pressure spiral hose, professional type. Made of kink- and abrasion-resistant material and therefore particularly robust. With hidden hard PVC spiral for resistant pressure and increased stability. This hose is perfect for suction purposes, as it does not constrict under vacuum. For pressure purposes and also suitable for drainage, pumping out, transferring and for emergency drainage depending on the size.

Length	Item no.	EAN / GTIN
5 m	31020	4011458310203

Hose connection

Ø 32 mm (1¼")



PRESSURE HOSE WITH CLAMP

10 metre pressure hose (flat hose) with Hose clamp Ø 32 mm for immediate use. Perfectly suitable for all types of drainage, e.g. pumping out and e.g. pumping out and pumping over pools.

Length	Item no.	EAN / GTIN
10 m	31096	4011458310968

Hose connection

Ø 32 mm (1¼")

CONNECTIONS



CONNECTING BENDS

	Size	Item no.	EAN / GTIN
	1 1/4" inside thread - 32 mm	30909	4011458309092
	1 1/2" inside thread - 38 mm	30910	4011458309108



DOUBLE NIPPLE

	Item	Size	Item no.	EAN / GTIN
①	Double nipple	1 1/2" outside thread - 1 1/2" outside thread	30921	4011458309214
②	Double nipple (140 mm long)	1" outside thread - 1" outside thread	30944	4011458309443



MULTI-DIMENSION CONNECTION PORT & CONNECTING BEND



	Item	Size	Item no.	EAN / GTIN
①	Connection port	1" inside thread - 3/4" outside thread / hose connections: 28 and 34 mm	30941	4011458309412
②	Connecting bend	1 1/4" IG - 3/4" outside thread / hose connections: 28 and 34 mm	30908	4011458309085
③	Connection port	1 1/4" AG - 3/4" outside thread/ hose connections: 28 and 34 mm	30920	4011458309207
④	Connecting bend	1 1/4" inside thread - 1" outside thread	30917	4011458309177



REDUCING NIPPLE & REDUCER

	Item	Size	Item no.	EAN / GTIN
①	Reducer	1 1/2" IG - 1 1/4" AG	30923	4011458309238
②	Reducing nipple	1 1/2" AG - 1 1/4" AG	30911	4011458309115
③	Reducer	1 1/4" IG - 1" IG	31095	4011458310951
④	Reducer	2" IG - 1 1/2" AG	31097	4011458310975

CONNECTIONS



COLLAR

	Item	Size	Item no.	EAN / GTIN
①	Collar (check valve)	1 ¼" inside thread - 1 ¼" inside thread	30924	4011458309245
②	Collar	1 ¼" inside thread - 1 ¼" inside thread	30945	4011458309450

STORZ COUPLING

Aluminium alloy Storz coupling for connection to pipes, containers, and devices. With seal for suction and pressure applications as standard..



	Item	Size	Item no.	EAN / GTIN
	C - Storz coupling	1 ½" inside thread	31094	4011458310944
	C - Storz coupling	2" inside thread	31092	4011458310920
	C - Storz coupling	2" outside thread	31093	4011458310937



IBC-CONNECTIONS

P1



IBC CONNECTION PORT

The special connection port for IBC tanks is perfectly suited for a fixed connection or piping for 1" connections.

Item no.	EAN / GTIN
30881	4011458308811

P2



3-WAY SPLITTER

High-quality 3-way splitter with 3 x 1" inside thread connections. All-purpose in conjunction with suitable 3 x 1" inside thread (30.93 mm) connection ports.

Item no.	EAN / GTIN
30882	4011458308828

P3



DOUBLE NIPPLE

Use the double nipple with 2 x 1" outside thread to screw and couple 1" inside thread (30.93 mm) connections.

Item no.	EAN / GTIN
30883	4011458308835

P4



BALL VALVE

The ball valve is equipped with 1" outside thread (33.25 mm) x 1" inside thread (30.93 mm) connections. 90° rotary drive, therefore complete closing (use as shut-off valve) possible

Item no.	EAN / GTIN
30884	4011458308842

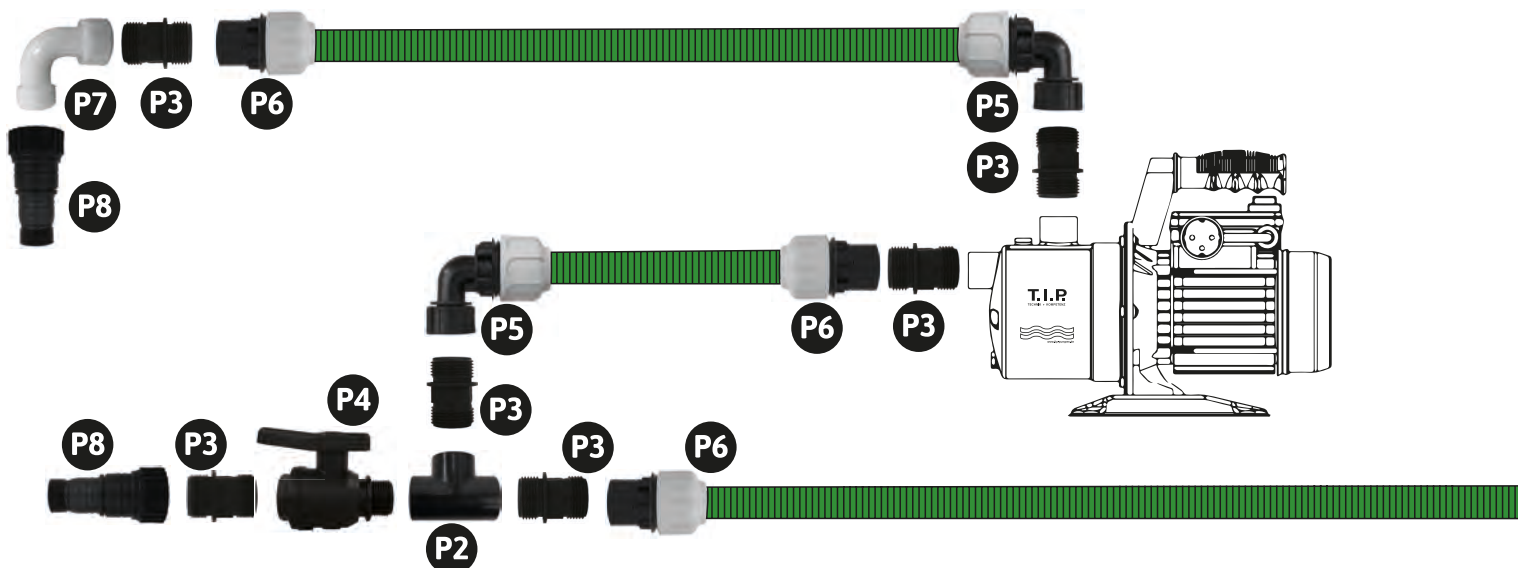

IBC-CONNECTIONS



QUICK HOSE CONNECTION PORT & CONNECTING BEND

The quick hose connection bend and the quick hose connection port are suitable for fast, space-saving connection of 25 mm (hose connection) / 1" inside thread (30.93 mm) hoses (sealed quickly and securely).

Item	Item no.	EAN / GTIN
① Connection bend	30885	4011458308859
② Connection port	30886	4011458308866



CONNECTING BEND

All-purpose 90° connecting bend.

Size	Item no.	EAN / GTIN
1" IG (30,93 mm) x 1" AG (33,25 mm)	30887	4011458308873



MULTI-DIMENSION PORT

The multi-dimension connection port enables connection to a 1" outside thread. Furthermore, it is perfectly suited to attach 32 mm or 38 mm hoses or a 3/4" outside thread (26.44 mm) connection to it.

Item no.	EAN / GTIN
30888	4011458308880



SELF-SEALING TANK CONNECTION

The self-sealing tank connection provides the easiest option for establishing connections to large tanks without countering from the inside (can be installed completely from the outside).

Item no.	EAN / GTIN
30889	4011458308897

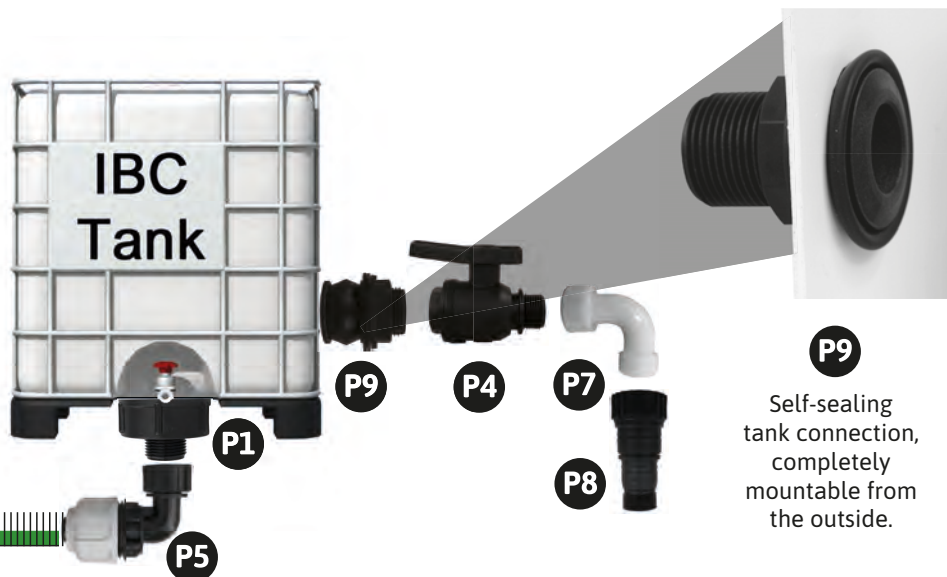

PRESSURE VESSELS



STEEL PRESSURE VESSELS

Complete with odour-free EPDM diaphragm that is made in Europe with flange and vessel valve.

Volume	Connection	Weight	Item no.	EAN / GTIN
22 l	33.25 mm (1" outside thread)	approx. 4.9 kg	30995	4011458309955
50 l	33.25 mm (1" outside thread)	approx. 7.7 kg	30957	4011458309573



STAINLESS STEEL PRESSURE VESSEL

Complete with odour-free EPDM diaphragm that is made in Europe with flange and vessel valve.

Volume	Connection	Weight	Item no.	EAN / GTIN
22 l	33.25 mm (1" outside thread)	approx. 4.5 kg	30996	4011458309962
50 l	33.25 mm (1" outside thread)	approx. 7.1 kg	30958	4011458309580



DIAPHRAGMS FOR DOMESTIC WATERWORKS

High-quality and odour-free EPDM pressure vessel diaphragms that are made in Europe. Suitable for installation in domestic waterworks.

Maximum liquid temperature: 90 °C
Wall thickness: 1.8 mm

Volume	Item no.	EAN / GTIN
15 - 25 l	30905	4011458309054
35 - 50 l	30956	4011458309566



ARMOURED HOSE

Flexible, rustproof connection hose. Quick and easy installation. Optimised for the connection between the water line and pump, boiler or pressure vessel. To distribute water in heating and air conditioning systems. Including seals.

Operating temperature: min. / max. -5 °C / +100 °C
Operating pressure: max. 10.0 bar

Connection	Length	Item no.	EAN / GTIN
30.93 mm (1" inside thread) / 33.25 mm (1" outside thread)	60 cm	30903	4011458309030



PRESSURE GAUGE

For exact pressure control. Measuring range up to a maximum of 6.0 bar.

Connection	Item no.	EAN / GTIN
13,16 mm (1/4" AG)	31003	4011458310036



PRESSURE SWITCH

Enables automation in conjunction with corresponding accessories (switching on/off).

Maximum liquid temperature: 35°C

Connection	Item no.	EAN / GTIN
11,89 mm (1/2" IG)	31002	4011458310029

PRESSURE VESSELS



NOTES

A large grid of small dots for taking notes, consisting of 20 columns and 30 rows of dots.

NOTES

A large grid of small dots for taking notes, consisting of 20 columns and 30 rows of dots.

NOTES

A large grid of small dots for taking notes, consisting of 20 columns and 30 rows of dots.

CONTACT

SERVICE HOTLINE FOR TECHNICAL QUERIES +49 7263 9125-50

Monday to Friday from 15:00 to 17:00

T.I.P. TECHNISCHE INDUSTRIE PRODUKTE GMBH

Siemensstrasse 17
74915 Waibstadt, Germany
Tel.: +49 7263 9125-0
Fax: +49 7263 9125-25
E-mail: info@tip-pumpen.de

SPARE PARTS AND REPAIRS

Please contact us by e-mail, fax, online or by post:

E-mail: service@tip-pumpen.de
Fax: +49 7263 9125-85
Post: T.I.P. Technische Industrie Produkte GmbH
Spare parts and repairs department
Siemensstrasse 17
74915 Waibstadt, Germany



Find us on social media



@tip.pumpen



tip.pumpen



T.I.P. Technische Industrie
Produkte GmbH

www.tip-pumps.com

Our website provides you with additional information and valuable tips regarding our products.



© T.I.P. Technische Industrie Produkte GmbH 2022
Catalogue attributes are not guaranteed. The specifications may change due to technical advancements. No liability for printing errors.
Design: T.I.P. Technische Industrie Produkte GmbH

THE PUMP PROFESSIONALS

T.I.P. Technische Industrie Produkte GmbH

Siemensstraße 17

D - 74915 Waibstadt

www.tip-pumps.com

Tel.: +49 7263 9125-0

Fax: +49 7263 9125-25

Email: info@tip-pumpen.de